

# **Beyond 5G White Paper Supplementary Volume “Sustainability and Energy Efficiency”**

**Version 1.0  
March 7, 2024**

**Beyond 5G Promotion Consortium  
White Paper Subcommittee**



<b>Preface</b> .....	<b>4</b>
<b>1. Introduction</b> .....	<b>4</b>
<b>2. Sustainability</b> .....	<b>7</b>
2.1 Sustainability in ICT industries .....	7
2.2 Sustainable 6G and 6G for Sustainability .....	11
2.3 Key Value Indicator .....	12
2.4 Sustainable AI .....	15
<b>3. Energy Efficiency</b> .....	<b>16</b>
3.1 Energy Efficiency goals for 6G .....	16
3.2 Technical Enablers for Energy Efficiency .....	19
3.2.1 Overall system perspective .....	19
3.2.2 Core Network Enablers .....	21
3.2.3 Radio Access Network Enablers.....	22
3.2.3.1 Optimal deployment planning technology for vRAN resources, exemplified by energy saving .....	22
3.2.3.1.1 Advancement of RAN operation management.....	22
3.2.3.1.2 Architecture of vRAN operation management .....	23
3.2.3.1.3 Process flow.....	23
<b>3.2.3.1.3.1 Configuration management information collection</b> .....	<b>24</b>
<b>3.2.3.1.3.2 Formulation of deployment plan</b> .....	<b>24</b>
<b>3.2.3.1.3.3 Optimal deployment calculation</b> .....	<b>24</b>
<b>3.2.3.1.3.4 Deployment execution</b> .....	<b>25</b>
3.2.3.1.4 Energy saving effect by optimal resource deployment.....	26
3.2.3.1.5 Conclusion.....	28
3.2.3.2 Other RAN architecture and deployment innovations.....	29
3.2.4 Air-interface Enablers.....	30
3.2.5 Coordination with Non-Terrestrial Network.....	34
3.2.5.1 Conventional O-RAN architecture and Requirement.....	35
3.2.5.2 Solution - Power Management for Base Stations Utilizing Pedestrian Flow Analytics and Non-Terrestrial Networks .....	35

3.2.5.3	Conclusion.....	37
<b>4.</b>	<b>Global Standards for Mobile Communication Networks.....</b>	<b>38</b>
4.1	Overall Trend of Energy Efficiency Standardization .....	38
4.1.1	3GPP .....	38
4.1.2	O-RAN Alliance .....	39
4.1.3	ITU and ETSI.....	40
4.1.4	IETF .....	40
4.2	Case Study on Energy Saving through utilization of O-RAN Alliance RIC Research and Development.....	41
<b>5.</b>	<b>Acknowledgements .....</b>	<b>45</b>
<b>6.</b>	<b>References .....</b>	<b>45</b>
<b>7.</b>	<b>Contributing Authors.....</b>	<b>49</b>
	<b>Abbreviation List .....</b>	<b>50</b>

**【Revision History】**

Ver.	Date	Contents	Note
1.0	2024.3.7	Initial version	

## **Preface**

Sustainability has been the foremost hurdle for humanity to overcome emerging change of climate and environment in the planet. As has been done by the other countries in a global partnership, Japan has been striving to make the planet and society sustainable. In the ICT industry, Energy efficiency as part of sustainability is of overarching importance to contribute to the goal of sustainable developments. Apart from that, more expanded role and contribution would be expected by leveraging mobile communication systems to evolve human life and society far more sustainable in Beyond 5G/6G era. The Beyond 5G white paper (version 2.0) published by Beyond 5G Promotion Consortium shed light on several technology and research directions towards energy efficiency as sustainability. The focus of this paper is to follow-up the technology direction and expose the cutting-edge technical enablers being extensively researched in academia and industry.

One deliverable is to crystallize the nomenclature of sustainability applied to the ICT industry, and potential actions taken by the ICT industry, that is, to minimize ICT footprint as well as maximize ICT handprint. A new concept to evaluate mobile telecommunication system capabilities from value-oriented viewpoints is explored, i.e., Key Value (KV) and its indicator (KVI). Use of AI is navigated with respect to sustainability, i.e., how AI should be accountable for fairness, transparency, security and privacy.

Another deliverable is a wide range of technical enablers for energy efficiency, encompassing the overall system in a holistic manner (CN, RAN, Air-IF and coordination with NTN). A quantified energy saving gain is shown for some advanced energy efficiency features. For instance, the optimal resource deployment technique for vRAN resources can reduce 37% of the power consumption in RAN. Another enabler to leverage pedestrian flow analysis and NTN can achieve up to 40% of the power saving.

Finally, standardization activities on sustainability and energy efficiency are outlined across key standardization organizations for the mobile industry. An analysis and performance evaluation are provided to envisage the energy saving gain by leveraging the energy efficiency features supported for RAN Intelligent Controller standardized by O-RAN Alliance.

## **1. Introduction**

Sustainable Development has been an imperative goal and action taken by all countries in a global partnership, such as tackling emerging climate change and

striving to preserve planet nature [1]. In fact, 2023 was the warmest year on record and close to 1.5 °C above pre-industrial level [2]. Similar climate change has been observed in Japan that the average annual temperature deviation in 2023 was + 1.29 °C over the average temperature for 30 years from 1991 to 2020, as in Figure 2-1. Further temperature rise would be foreseen if the current situation would be remained as it is.

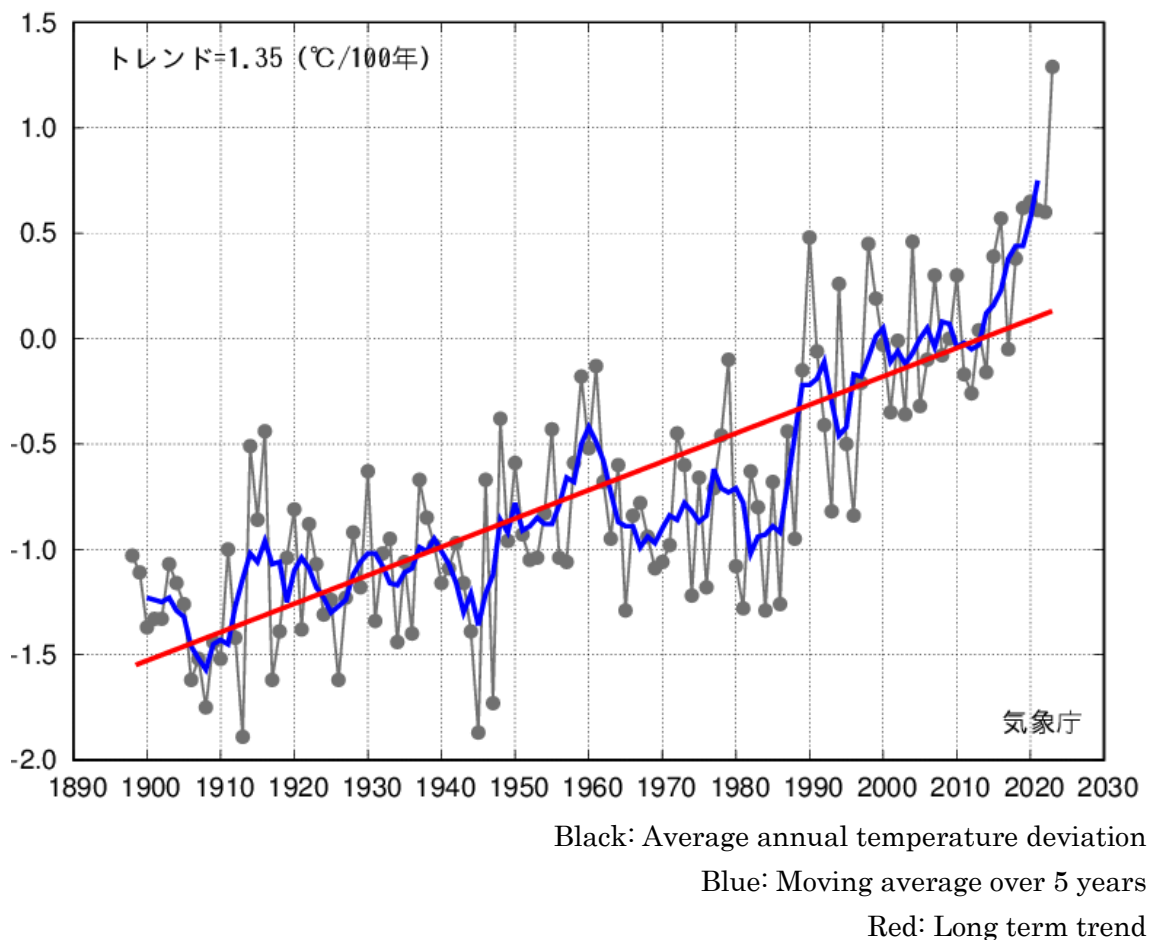

Figure 1-1: Averaged annual temperature deviation in Japan [3]

To wrestle with the climate change, Japanese government has pledged to become a carbon neutral society, i.e., to reach net zero emissions by 2050, in accordance with Paris agreement [4]. The goal towards net zero emission is also an imminent challenge for the Information and Communication Technology (ICT). From 2000s to today, the ICT footprint has almost doubled over the world. Likewise in Japan, a significant increase in power consumption is predicted by ICT related equipment (infrastructure and end user devices) as communication traffic grows (see Figure 2-2 [5]) unless technical innovations can overcome the expected higher power consumption.

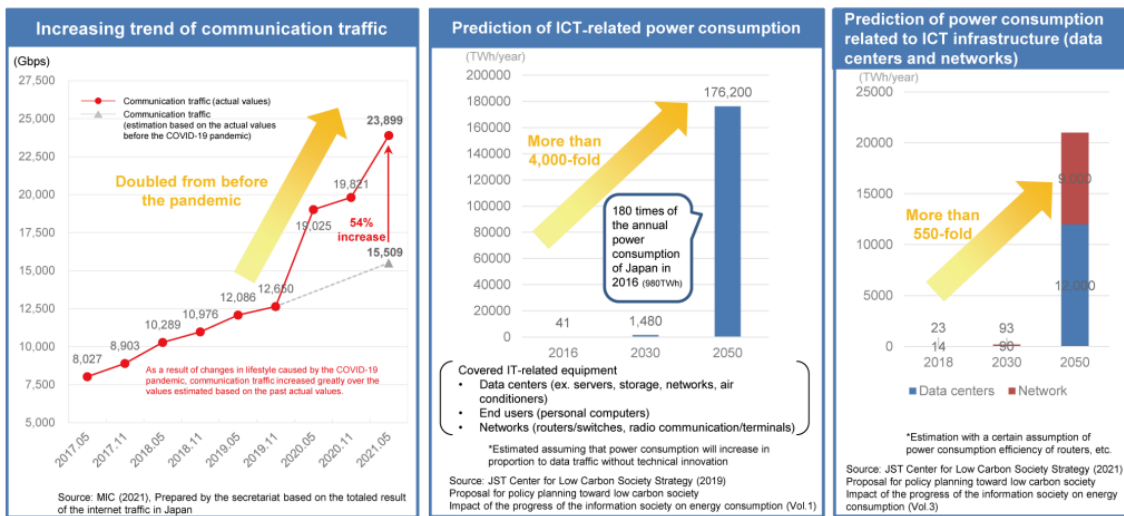

Figure 2-2: Trends of communication traffic and energy consumption in the ICT sector (Source: MIC, the Department of Information and Communications Technology of the Information and Communications Council, materials of the 27th technology strategy committee [5])

To explore the technical innovations toward energy efficiency and sustainable development, several technology and research directions are provided in the Beyond 5G White Paper [6]. As a follow-up study, the focus of this white paper is to identify and expose key technology enablers for sustainability and energy efficiency towards 6G. Section 2 attempts to crystallize the sustainability for the ICT industry and actions taken for the sustainable mobile networks. Section 3 disseminates the cutting-edge technical enablers for energy efficiency being extensively researched in academia and industry. Finally, Section 4 looks over the global standardization for mobile communication networks.

## **2. Sustainability**

The term sustainability per se is a broad concept and often encompasses environmental, economic and societal practices for operating a business, all of which are grappled by UN SDGs [1]. This section attempts to crystallize the nomenclature of sustainability applied to the ICT industry and 6G. Given the gaining momentum that AI will be an integrated part of all future systems, key design principles are presented as to how fairness, transparency, security, privacy and energy aware deployments of AI systems should be ensured.

### **2.1 Sustainability in ICT industries**

Sustainability focuses on how the present needs can be fulfilled without compromising the ability of future generations to meet their own needs. Sustainability is a critical part of business models and strategies with meaningful risks and opportunities, going far beyond simply doing good and compliance. The ICT and mobile industries play a vital role in satisfying environmental sustainability. Environmental sustainability focuses on protecting the three key diversities of our planet as illustrated in Figure 2.1-1: air, biological living forms and geodiversity of many materials on the earth. The air is the mixture of gases that surrounds earth, which contains important substances, such as oxygen, nitrogen, and carbon dioxide. The air enables a stable environment to live and operate businesses, which is essential for life to grow and survive. The biodiversity denotes the variety of life forms and eco-systems on earth which are providing many essentials elements and services like medicines, clothes, building materials, fuels, carbon capture (natural defense against climate change), etc. The geodiversity covers non-biological aspects of nature, such as metals, minerals, and water. These three diversities are interconnected with each other, and strongly affected by major drivers coming from human activities; the growing rate of Green House Gas (GHG) emission leading to climate change, the use and change of land use like deforestation, the resource use with both their extraction and their usage, and the generated pollution and waste from human activities. To downsize these higher risks and impacts, circularity and energy use are the two most important fields where the ICT and mobile industries can contribute and facilitate higher efficiencies and waste reductions.



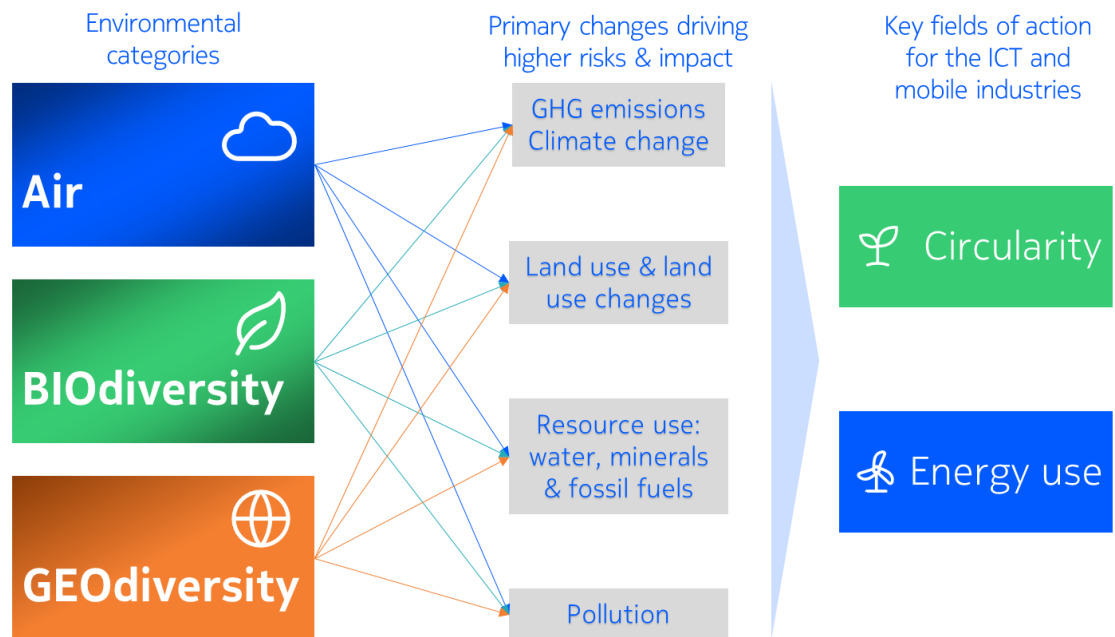

Figure 2.1-1: Environmental sustainability and key fields of action

The strategies taken for circularity and energy are as follows [7].

**A. Minimizing ICT footprint**

The global ICT industry is mainly powered by electricity, accounting for up to 5% of the world's electricity consumption [8]. GHG emissions from the global ICT industry are up to 2% of the world total emission. The detailed components of electricity consumptions and GHG emissions in the ICT sector is shown in Table 2.1-1 [8].

Table 2.1-1: Global estimates of ICT sector emissions, 2020 to 2022 [8]

Industry	Emissions 2022/2020 (million tCO <sub>2</sub> e)			Change 2022/2020 %	Electricity (TWh)			Change 2022/2020 %
	2020	2021	2022		2020	2021	2022	
Telecommunications operators	135	134	133	-1%	239	255	258	8%
Colocation data centers	36	40	43	20%	89	100	109	22%
Cloud & content	22	27	32	46%	54	70	85	63%
<b>Subtotal</b>	<b>193</b>	<b>201</b>	<b>208</b>	<b>8%</b>	<b>382</b>	<b>425</b>	<b>442</b>	<b>18%</b>
% of world	0.6%	0.6%	0.6%		1.60%	1.70%	1.70%	
<b>ICT Equipment</b>	<b>154</b>	<b>173</b>	<b>154</b>	<b>0.5%</b>	<b>282</b>	<b>329</b>	<b>311</b>	<b>10.6%</b>
- PCs	62	71	65	4.8%	110	133	124	
- Smartphones	60	64	57	-5.1%	116	131	119	<b>2.5%</b>
- Network	32	38	33	2.4%	56	65	69	<b>22.0%</b>
Product use	222	215	205	-7.5%	430	442	430	<b>-0.1%</b>
- PCs	203	197	187	-7.9%	394	405	392	<b>-0.5%</b>
- Smartphones	19	18	18	-3.4%	36	37	38	<b>4.3%</b>
<b>Subtotal</b>	<b>375</b>	<b>388</b>	<b>359</b>	<b>-4.2%</b>	<b>712</b>	<b>771</b>	<b>741</b>	<b>4.1%</b>
% of world	1.2%	1.1%	1.0%		3.0%	3.0%		
<b>TOTAL</b>	<b>568</b>	<b>589</b>	<b>567</b>	<b>-0.2%</b>	<b>1094</b>	<b>1196</b>	<b>1183</b>	<b>8.2%</b>
% of world	1.8%	1.7%	1.7%		4.6%	4.7%		

Furthermore, the ICT industry has been generating an increasing amount of electronic waste due to accelerated digitalization. On the network side, the share of GHG emission, combining both fixed and wireless networks, is up to a quarter of the total ICT GHG emission impact. The GHG emission from NW is mainly coming from its operational phase, and less from the manufacturing of the NW elements. The GHG emission from NW is then highly dependent on its operation, i.e., NW electricity consumption. The NW energy efficiency as well as the carbon emission intensity of the electricity powering the NW, affects the GHG emission level. Thus, the industry should strive for minimizing any negative impact to GHG emissions and achieving significant reduction of its direct and indirect GHG emissions.

Potential approaches are exemplified as follows.

- i. Building sustainable operations and supply chain.
- ii. Continually improving product energy efficiency.
- iii. Driving circularity to reduce waste.
- iv. De-risking the potential misuse of technology (e.g., responsible use of AI [9]).

### ***B. Maximizing ICT handprint***

In addition to minimizing the ICT footprint, any positive impacts to the environment and ecosystem have to be maximized, i.e., ICT handprint

maximization. Potential approaches to maximize ICT handprint are exemplified as follows.

- i. Enabling 24/7 low carbon and renewable energy systems.
- ii. Decarbonizing other industries and society.
- iii. Enabling the transition of the energy sector.
- iv. Providing the critical networks for life with low energy consumption and high energy efficiency.
- v. Connecting the unconnected through ubiquitous connectivity and education as well as building digital skills.

Once the target fields and strategies are determined, the next question of interest is how to measure the actions taken for ICT footprint and handprint. ESG is the broad rating of commitment to sustainability and other values [10]. ESG is the abbreviation for the set of Environmental, Social and (corporate) Governance. “Environmental” represents any actions to protect and regenerate the natural world, e.g., climate change, reduction of GHG emissions, air and water pollution, water scarcity and deforestation. “Social” is aimed at ensuring human centric objectives, including human rights and equality of opportunity for everyone, regardless of age, gender, race ethnicity and region. The social practices also cover personal data protection and privacy, product safety, mental health and community impact. Corporate governance denotes the governance and ethical practices to ensure sustainability in the business and corporate world, e.g., responsible sourcing, reporting, transparency, compensation and accountability to ethics, anti-corruption, health, safety and cyber security. Key components for which ESG is targeted are illustrated in Figure 2.1-2.

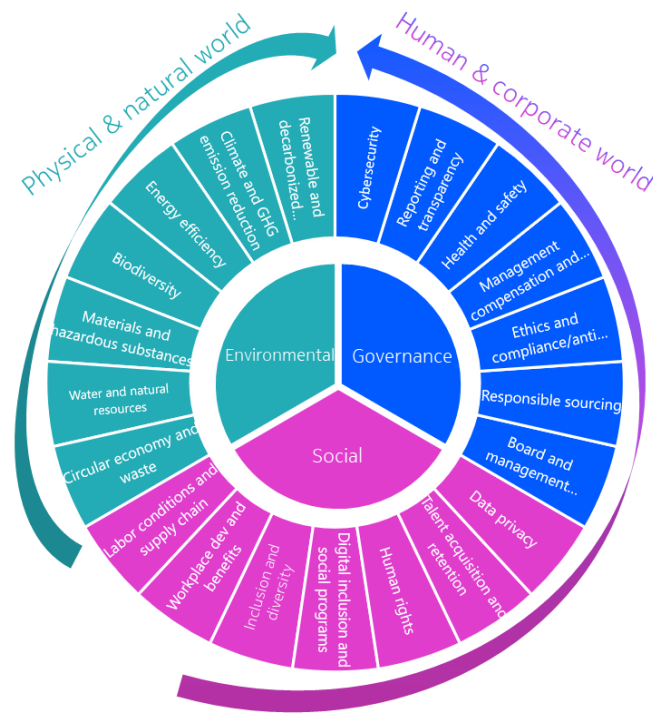

Figure 2.1-2: Overview of ESG

## 2.2 Sustainable 6G and 6G for Sustainability

Whilst the commercial 5G services have successfully evolved, academia and industry are moving ahead towards 6G research and standardization. ITU-R WP5D agreed on IMT-2030 framework covering usage scenarios and capabilities in June 2023 [11]. Sustainability was identified as one of the motivations and societal considerations for the development of IMT-2030. Sustainability, or more specifically environmental sustainability, was defined as one of the new capabilities to support the expanded usage scenarios of IMT-2030. Thus, 6G per se needs to be capable of achieving sustainability in ICT industries as described in subsection 3.1, e.g., minimizing the ICT footprint by reducing GHG emissions and energy consumption from the ICT infrastructure, which is termed as “Sustainable 6G” [12]. The Sustainable 6G would contribute to the first order of effects for the life cycle impact of ICT goods, networks and services as defined by ITU-T [13]. In Recommendation ITU-T L.1410, the first order effect is defined as follows.

- *The impacts created by the physical existence of ICTs and the processes involved, e.g., energy consumption and GHG emissions, e-waste, use of hazardous substances and use of scarce, non-renewable resources.*

Besides that, 6G technologies and deployments can contribute to maximize the handprint, as described in subsection 3.1, e.g., decarbonizing other industries and

society, enabling the energy sector transition, providing global connectivity, etc., which is termed as “6G for Sustainability” [12]. The 6G for Sustainability would contribute to the second order effects and, to some extent, other effects defined in ITU-T L.1410, as listed below.

- *Second order effects: the impacts and opportunities created by the use and application of ICTs. This includes environmental load reduction effects which can be either actual or potential, such as travel substitution, transportation optimization, working environment changes, use of environmental control systems, use of e-business, e-government, etc.*
- *Other effects: the impacts and opportunities created by the aggregated effects on societal structural changes by using ICTs. Particularly for some ICT services such as teleworking or videoconferencing, the time gained by an end user using an ICT service which then may cause additional impact e.g., a leisurely drive and economic activities, which are difficult to track. Such additional impacts are often defined as "rebound effects".*

Both sustainable 6G and 6G for sustainability are the twin pillars of any technology evolution and revolution towards 6G.

### **2.3 Key Value Indicator**

For the existing capabilities supported from the legacy IMT technologies (up to 5G), performance-oriented values were the key metrics to evaluate technology potentials, such as peak data rate, spectrum efficiency, latency, and so on. Whilst the performance-oriented value is valid for 6G to judge the enhanced capabilities as in Figure 2.3-1, it would not be able to properly evaluate the new IMT-2030 capabilities, especially for sustainability. Value-oriented indicators are deemed as necessary to evaluate if the candidate features for 6G can offer sustainable 6G and/or 6G for sustainability described in subsection 2.2.

## Capabilities of IMT-2030



The range of values given for capabilities are estimated targets for research and investigation of IMT-2030.

All values in the range have equal priority in research and investigation.

For each usage scenario, a single or multiple values within the range would be developed in future in other ITU-R Recommendations/Reports.

So called "Palette diagram"

Figure 2.3-1: Capabilities of IMT-2030

6G pre-research initiatives in several regions have been studying how to define value-oriented indicators, as Key Values (KV) and its Indicators (KVI) and how the concept of KV and KVI can be integrated with the existing performance-oriented KPIs [14 - 16], albeit this is still in an early application stage. Figure 2.3-2 illustrates an example of the role of KV to assess sustainability, trustworthiness and inclusiveness defined by UN SDGs and how it is integrated into the evaluation methodology for 6G use cases and technologies [14].

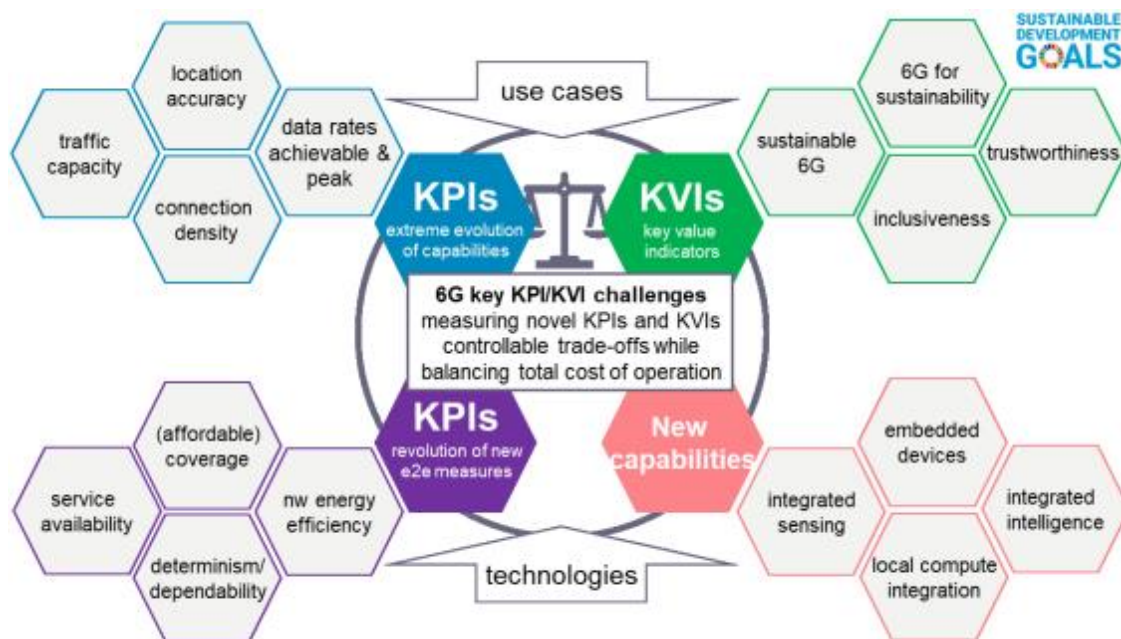

Figure 2.3-2: Example of clustering KPIs and KVs [14]

Table 2.3-1 shows a set of KV examples for some use case areas [17]. The introduction of KVIs in conjunction with the traditional KPIs enables to evaluate 6G technologies and use cases if they can address human and societal challenges from the needed viewpoints (sustainability, trustworthiness and inclusiveness). With regards to KVI standardization, 3GPP has started to study how to introduce KV and KVIs with respect to the upcoming 6G standards [18].

Table 2.3-1: KV examples

Use case area	KV examples	KVI examples
Emergency response & warning systems	<b>Societal sustainability</b>	<i>Reduced emergency response times; Increased operational efficiency of interventions in remote areas</i>
	<b>Environmental sustainability</b>	<i>Increased area of protected and surveyed natural habitats and climate preserves</i>
	<b>Trust</b>	<i>Reported confidence in advanced digital devices, systems, and services in critical missions</i>
Smart city with urban mobility	<b>Environmental sustainability</b>	<i>Environmental footprint of urban transport of persons and goods</i>
	<b>Personal health and protection from harm</b>	<i>Injuries in urban traffic</i>
Personal health monitoring & actuation everywhere	<b>Privacy and confidentiality</b>	<i>Reported user control of medical data for storage/transmission/processing</i>
	<b>Societal sustainability</b>	<i>Average cost saving in health care system per patient</i>
	<b>Trust</b>	<i>Reported trust level for autonomous e-health components; Accuracy rate in e-health AI-related events' identification and/or decision making</i>
Living and working everywhere	<b>Societal sustainability</b>	<i>Travelling / commuting time reduction; Access to job market; Life opportunities in rural areas</i>
	<b>Economical sustainability and innovation</b>	<i>Cost-efficiency of living and working in rural areas; Number of activities that can be performed anywhere</i>
	<b>Digital inclusion</b>	<i>Access to internet in communities and areas</i>
Sustainable food production	<b>Environmental sustainability</b>	<i>Environmental footprint of agriculture activities; Energy use in agricultural activities</i>
	<b>Societal sustainability</b>	<i>Increase in agriculture productivity; Reliability of food production</i>

## 2.4 Sustainable AI

AI is considered as a key technology enabler for designing multiple aspects of the future 6G networks like coverage adaptation, resource allocation, security, multi-domain orchestration. Aspects of AI design like fairness, transparency, security and privacy are paramount for implementing fair, inclusive and secure services. There should be mechanisms to identify and remove undesirable algorithmic bias that creeps into AI systems due creation of generalized models based on finite training data. Implementations of AI systems should be accountable for their outcomes, therefore explainability and traceability are key aspects in implementing critical communication systems. An unwanted side effect is that the same AI mechanisms that enable many sophisticated 6G features also opens another surface for security attacks and therefore mechanisms need to be studied to consider and overcome this challenge [19]. Since collection of data from users and other sources is key for the implementation of AI models, the design and architecture for collection and transport of data and models need to consider ensuring that privacy of user data is not compromised.

In addition, due to its compute-intensive nature, the energy footprint of AI implementations is becoming a significant component of the energy budget of the overall system. With “digital compute”, the energy needs keep scaling up with the ever-increasing sophistication of tasks; and techniques like Analog Compute [20] need to be studied for developing hardware platforms for AI.



### 3. Energy Efficiency

Energy efficiency, i.e., to save energy consumed in mobile communication systems is of paramount importance for sustainable 6G explained in subsection 3.2. This section provides an analysis of the current energy consumption in the mobile network and a potential energy efficiency target for 6G. In addition, technical enablers for energy efficiency are disseminated from a wide range of technology potentials being extensively researched in academia and industry.

#### 3.1 Energy Efficiency goals for 6G

First of all, in order to set the design goal of energy efficiency towards 6G, it is sensible to learn how the energy is being consumed in the current mobile networks. Figure 3.1-1 shows the energy consumption for a typical CSP, based on a survey conducted by NGMN [21] in 2021 over 30 networks with a mixture of multiple generations and multiple radio access technologies across different domains of operations. It becomes clear that most of the energy consumption for a CSP is in network operations, amongst which the RAN infrastructure consumes the largest amount of energy. Besides that, the radio part, which corresponds to the RU, consumes 29% of energy which is the same amount of energy consumed by BTS air conditioning. With the on-going rollout of the larger massive MIMO (mMIMO) RUs and the corresponding shift of processing functionality into the RU, the share of RU energy consumption will continue to grow in coming years.

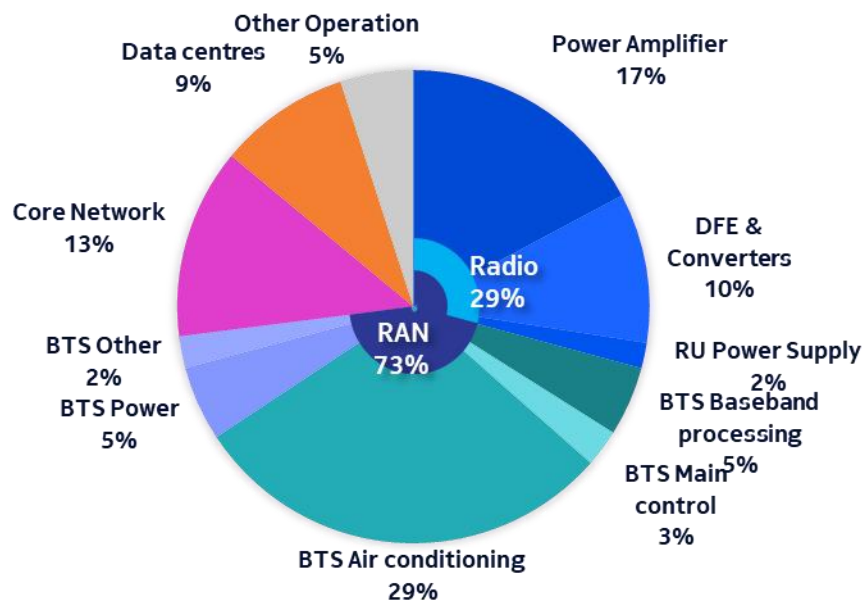

Figure 3.1-1: Distribution of energy consumption for CSP operators (based on data from [21])

Figure 3.1-2 further breaks down the proportion of the power consumed by different components at 100% load. The majority of the power consumption is stemmed from the PA, Digital DFE and RFIC, which includes the converters, the interpolation, digital pre-distortion and crest-factor reduction, and the digital processing integrated circuit that performs L1-low signal processing functions including Fast FFT processing, beamforming, channel estimation and the first stage of MIMO detection.

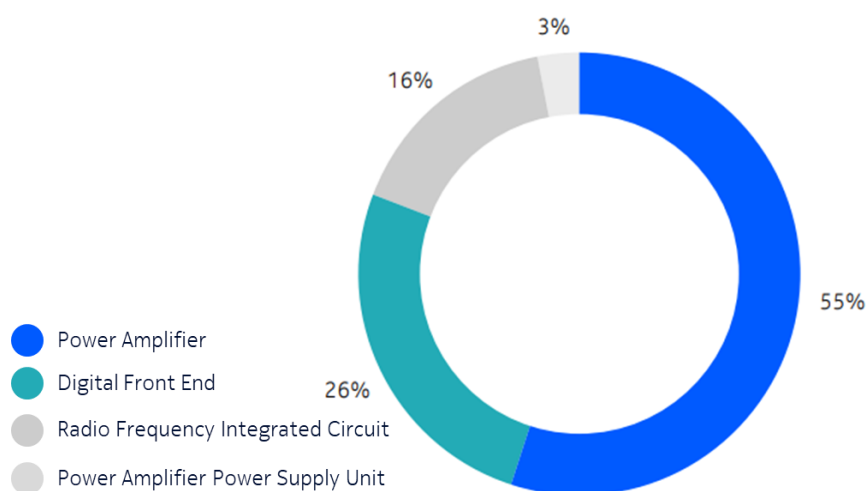

Figure 3.1-2: mMIMO RU power consumption split at 100% load

Although the RU power consumption distribution in Figure 3.1-2 is based on a full load situation, the RU, in practice, rarely operates at its peak load. There is a survey on the aggregated network traffic profile of Europe BS sites that 80% of BS sites carry only 20% traffic, and the rest of 20% BS sites are busy in carrying 80% of traffic as shown in Figure 3.1-3 [22]. 20% of BS sites only take 1% of traffic, which can be regarded nearly in idle mode. Furthermore, the traffic load varies substantially over the daily 24-hour period even at the same BS site. This traffic trend and characteristics can give a hint that a potential target to save energy consumption would be the case where and when middle or low traffic is observed.

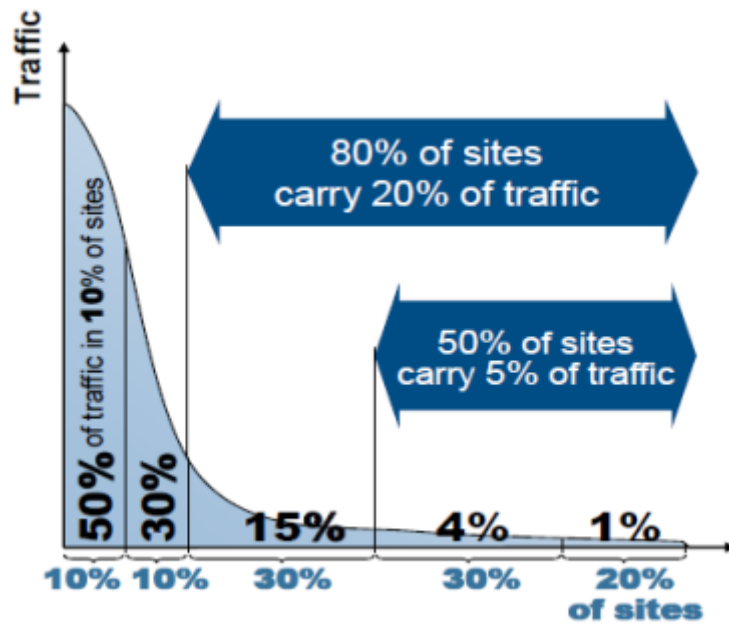

Figure 3.1-3: Aggregated network traffic profile of Europe BS sites [18]

Figure 3.1-4 illustrates a target power consumption for a 6G extreme mMIMO RU (denoted as xMIMO in the figure) by the relative power consumption of a single carrier for a 5G mMIMO RU as a function of the cell capacity [23]. The peak capacity of 6G extreme mMIMO with 400 MHz bandwidth and 128 TRX will be 6.7 times higher peak capacity of 5G mMIMO with 100 MHz bandwidth and 64 TRX. On the other hand, if the 6G xMIMO RU were built upon the existing technologies, the energy consumption at the peak capacity would grow 3 times larger than that of the existing 5G mMIMO RU. If the advanced energy efficiency techniques are leveraged, the power consumption of 6G xMIMO RU can be mitigated to the level of 2 times increase from the existing 5G mMIMO RU. Moreover, when the offered load for the 6G cell is less than the peak capacity of a 5G cell, 6G system should consume substantially less power than the 5G cell as illustrated in Figure 3.1-4. In particular, the power consumption should gracefully approach the cell switch-off power with decreasing load. The goal should be to approach an exponential drop in energy consumption as the load decreases from the high loads and near linear scaling of energy consumption at low loads.

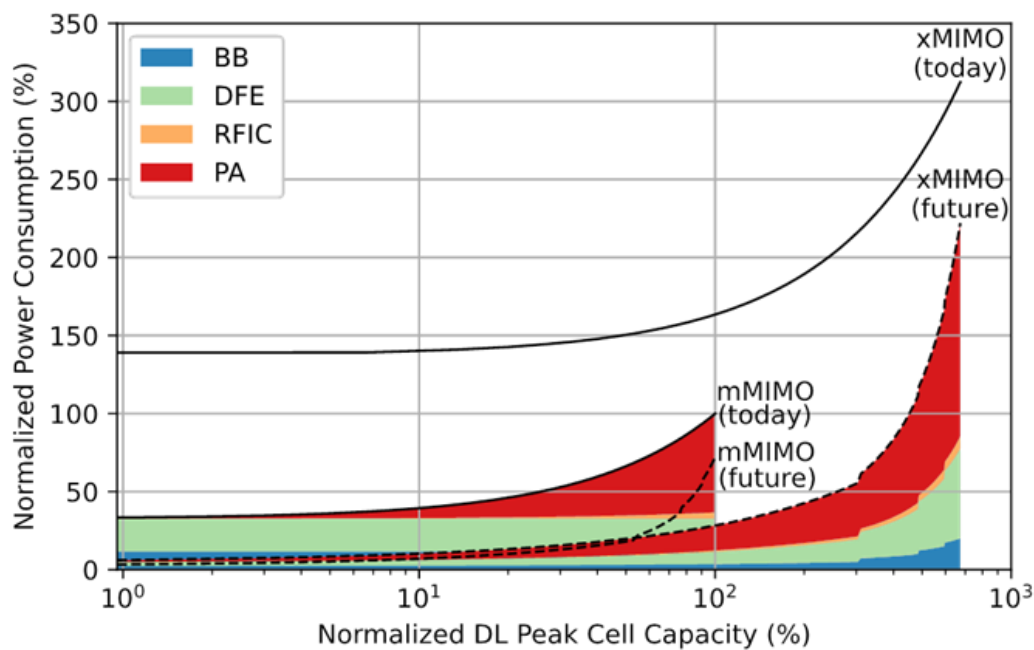

Figure 4-4: 6G power consumption goal versus 5G [23]

On the other hand, the energy efficiency goals may require some trade-offs in performance. It is up to use cases and type of services being provided which performance degradations are acceptable and to what extent. For instance, 3GPP has made a formal statement that the energy efficiency aspects of a solution in defined in 3GPP is not to be interpreted to take priority or to be alternative to security, privacy, complexity, etc., and to meeting the requirements and performance targets of the specific feature(s) the solution addresses [24]. Therefore, the performance goal and energy efficiency goal need to be well balanced, when applying energy efficiency solutions for a given use case.

## 3.2 Technical Enablers for Energy Efficiency

### 3.2.1 Overall system perspective

Although the energy consumption in RAN is dominant in mobile networks as exemplified in section 4, the energy consumption from the other portion such as Core Network (CN) and data centers cannot be ignored, due to the predicted increase driven by emerging requirements of cloud native network functions and applications. Edge clouds and edge traffic processing would also be another potential impact to the predicted energy increase. Hence, a holistic strategy and approach are imperative to ensure the end-to-end system wide energy efficiency of 6G system can be achieved. Figure 3.2-1 shows the central pillar of Green 6G enablers, i.e., energy efficiency enablers.

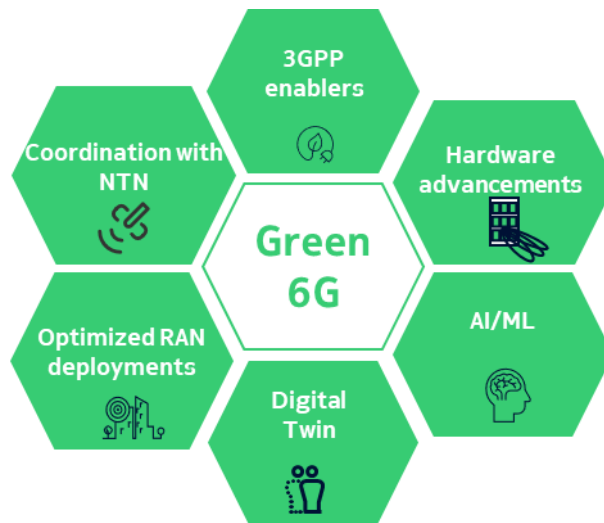

Figure 3.2-1: Overall system level enablers for Green 6G

### ***A. 3GPP enablers***

3GPP enablers driven by IMT-2030 requirements, such as EE requirements and KVIs, leverage the energy saving techniques for UE and NW supported in 5G and 5G-Advanced, which will be a baseline for overall 6G system design toward energy efficiency. In addition, Green 6G design (radio, architecture and CN) can offer the following standardized functionalities.

- Multi-layer optimized tradeoff of spectrum efficiency versus energy efficiency.
- Leaner carrier, wave forms and modulations for low energy use.
- QoS adaptation based on load and network energy saving state.
- NF energy exposure to enable dynamic optimizations via AI/ML.

### ***B. Hardware advancements***

Hardware advancements are a viable enabler, especially for the air interface domain, such as fast (deep) sleep modes, advanced power amplifiers, hybrid beamforming architectures for low digital complexity and enhanced digital frontend processing. The advanced hardware design is expected to be driven by vendor innovations in a competitive manner. Potential innovation directions are as follows.

- Energy saving and scheduler innovations.
- Advanced signal processing.
- Smart work-load balancing.
- Green energy site solutions (virtual power plant, liquid cooling, etc.)
- Enhanced MIMO radios designed with state of art technology components and architectures enabling increased energy saving gains.

### ***C. AI/ML***

AI/ML is expected to be a native capability for 6G system. The integrated AI/ML to 6G system can be leveraged to select and optimize energy saving algorithms based on predictions of traffic, radio conditions and mobility.

#### ***D. Digital twin***

Digital Twin enables multi-purpose virtual network emulations, e.g., for testing energy saving algorithms and optimizations reducing lab and field-testing efforts.

#### ***E. Optimized RAN deployments***

RAN and spectrum deployments can be optimized by taking into account energy use. For instance, coverage, cell/area capacity, interference and mobility are fine-tuned not only for performance, but also taking balance with energy efficiency.

#### ***F. Coordination with NTN***

Due to wider coverage offered by satellite access (aka NTN), NTN coverage can be leveraged to save the energy consumption in RAN, e.g., when traffic load is expected to be low and BSs are turned off. How to save BS power consumption and leverage NTN is elaborated in section 3.2.5.

### **3.2.2 Core Network Enablers**

The current 5G Core Network, aka 5GC, standardized by 3GPP up to Rel-18 specification has already supported features contributing to energy efficiency, e.g., NF scaling in operations. 3GPP has been continuously addressing energy efficiency solutions and currently studying the following areas from system and CN perspectives towards Rel-19 specification [25].

- Framework for NW energy consumption exposure.
- Subscription and policy control to enable NW energy savings as service criteria.
- 5G system enhancements toward energy saving, e.g., energy usage adjustment for NF from CN aspect, energy saving related decision making, NF selection leveraging NF energy states, analytics, etc.

On the NW energy consumption exposure, one potential approach is to define an open API on compute utilization rates and energy consumption metrics associated with different NFs, in order to enable monitoring and traceability of energy expenditure. Correlation of energy consumption with traffic load and required compute capacity can provide means for better optimizing allocation of resources. It is also worthwhile extending the open API to interact with energy information topics related to building, surrounding infrastructure, street gadgets, etc.

The on-going energy efficiency standardization for 5G-Advanced is a steppingstone toward 6G, and further evolutionary or revolutionary innovations would be envisaged. Some technology directions are as follows.

- End-to-End coordination across, UE, RAN, CN and edge to avoid domain-specific energy saving measures that indirectly cause increased overall energy consumption.
- Energy optimized CN protocols and procedures, e.g., simplified procedures, analytics-based CN power saving mode, etc.
- Energy saving via network sharing and roaming.
- Energy efficiency via integration of NW and compute.

### **3.2.3 Radio Access Network Enablers**

#### **3.2.3.1 Optimal deployment planning technology for vRAN resources, exemplified by energy saving**

It is anticipated that the digitalization of society and the introduction of 5G and Beyond 5G will pose challenges to the provision of new services in network systems that rely on traditional dedicated devices. The first challenge is the expected increase in communication traffic and the associated increase in power consumption of network devices, due to the proliferation of IoT devices, connected cars, and 5G smartphones, as well as the increase in high-quality image and sound data. The second challenge is that the configuration of the network is becoming complex, making it increasingly difficult to operate manually or to develop/purchase systems by a single vendor.

To address these challenges in the telecommunications industry, the O-RAN Alliance is promoting the opening up of communication networks and their intelligentization using AI/ML. With the spread of O-RAN, operators can achieve cost reduction and operational efficiency, while vendors can achieve product development and ecosystem construction. On the other hand, a major trend in recent communication systems and networks is the transition from dedicated hardware devices specialized for communication to a virtualization platform based on general-purpose IA servers, and the use of cloud services that enable flexible service provision and scalability is advancing. Therefore, even in RAN operations, it has become possible to shift from traditional fixed operations to dynamic operations.

##### **3.2.3.1.1 Advancement of RAN operation management**

To solve these challenges, we are working with the "network service infrastructure technology to realize optimal deployment of vRAN resources" that complies with O-RAN specifications for ultra-high-speed, large-capacity wireless access networks. This

"network service infrastructure technology to realize optimal deployment of vRAN resources" enables safe and automatic redeployment of vRAN resources according to their purpose (for example, energy saving, local traffic increase, equipment failure, etc.). In this section, we will describe the case for energy saving.

### 3.2.3.1.2 Architecture of vRAN operation management

In the "network service infrastructure technology to realize optimal deployment of vRAN resources", we added a rApp that realizes the "resource planning function" and "resource controller function" on the Non-RT RIC framework inside the SMO in the O-RAN architecture. Figure 3.2.3.1.2-1 shows a schematic diagram of this technology.

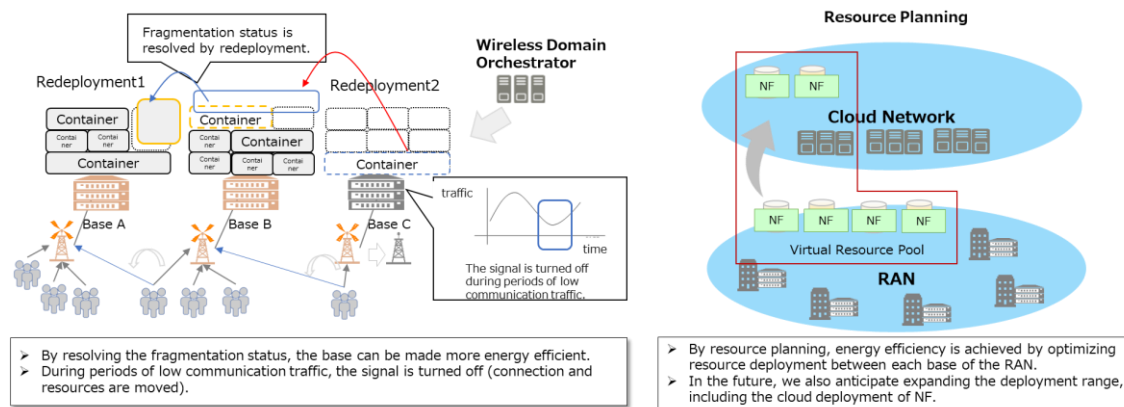

Figure 3.2.3.1.2-1: Schematic diagram of this technology

In this way, we have built a cycle of data collection, analysis, and setting changes based on the analysis results. The functions of the added rApp are as follows.

- Resource planning function

We will implement energy saving designs (accommodation design and antenna settings) for wireless access networks (antennas, virtual servers, etc.) according to traffic demand.

- Resource controller function

It collects the resource information on O-RAN necessary for power optimization and safely and reliably reflects the design results in the network.

### 3.2.3.1.3 Process flow

The process flow of this rApp is as follows.

1. Configuration management information collection
  2. Formulation of deployment plan
  3. Optimal deployment calculation
- } resource planning function



#### 4. Deployment execution

resource controller function

##### 3.2.3.1.3.1 Configuration management information collection

In order to use the optimal deployment configuration derived from the optimization calculation and the obtained calculation results for the deployment process that reflects them in the network topology, we collect the O-RAN resource information (physical resources/virtual resources) of the wireless access network and the vRAN topology information (configuration information of RU/DU/CU). Here, since the rApp collects information through the interface standardized by O-RAN, it enables the collection of configuration information that is compatible with multiple vendors.

##### 3.2.3.1.3.2 Formulation of deployment plan

We utilized AI to collect and analyze radio usage information gathered from RUs and DUs, and to determine the trigger for demand forecasting of wireless resources and deployment execution. Specifically, in formulating the RU stop radio transmission plan, we adopted the CK-MARL, a performance-guaranteed multi-agent reinforcement learning technology as an inference model, in order to prevent the degradation of NW communication quality due to the execution of RU stop radio transmission control and to reduce the wide-area large-scale calculation time without falling into a local optimum. This CK-MARL has the features of performance guarantee of the specified KPI and coordinated distributed control by multiple AIs [26]. This allows us to formulate deployment plans from the RU stop-wave plan that ensures NW communication quality and meets the overall optimization in real-time processing.

##### 3.2.3.1.3.3 Optimal deployment calculation

We collect information on the RU, physical layer, and virtual layer of the deployment area from the configuration management function, gather link (connection) information between each entity and attribute information of each entity, and calculate the optimal deployment configuration with power saving as the evaluation index. Figure 3.2.3.1.3.3-1 shows an overview of the calculation of the optimal deployment configuration.

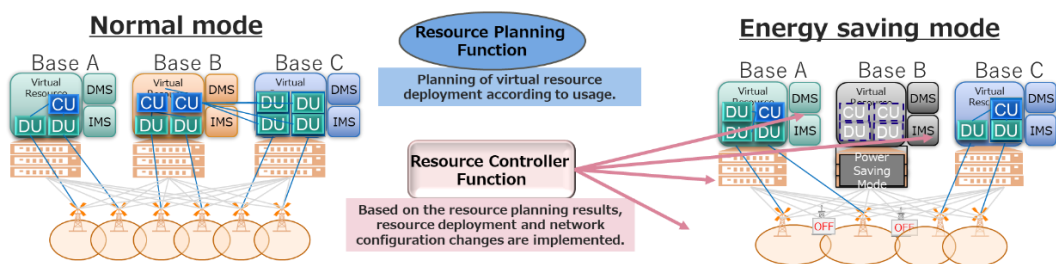

Figure 3.2.3.1.3.3-1: Deployment configuration calculation overview diagram

The deployment configuration calculation is calculated in the following two steps.

- ① Derive the optimal combination for multiple cells (RU) that the DU accommodates.
- ② From the calculation results of ①, derive the optimal combination for the CU that connects to the DU where the cell is accommodated.

In deriving the optimal combination, we apply quantum computer technology that can quickly solve combination optimization problems that are difficult to solve with current general-purpose computers.

#### 3.2.3.1.3.4 Deployment execution

Next, based on the results of the optimal deployment calculation, we reconstruct the servers where the RU/DU/CU, which are components of the wireless access network, are implemented, and the switches on the route. In reconstructing this new network topology, it is necessary to consider multi-vendor considerations and control considering the impact on service to users. In addition, it is necessary to shorten the operation time as the control target is expected to become enormous. To achieve these, the resource controller function has the following functions. The resource controller function consists of various control functions that control each element (server/DMS/vRAN/switch/RU) and a deployment execution function that governs them.

- ① Automatic creation of various config information and control commands necessary for reconstruction
  - Corresponding to networks that vary by cloud
  - Multi-vendor compatibility
  - Automatic creation of config files and deployment scripts
- ② Determining the control order of the reconstruction target grouping.  
Grouping is the extraction of groups that can be executed in parallel from the configuration information list to shorten the reconstruction time. The control for the components of the wireless access network is as shown in Table 3.2.3.1.3.4-1. In order to minimize the impact on service to users, it is necessary to consider the order of control.

Table 3.2.3.1.3.4-1: List of controls implemented by this rApp

Control target	Control content
----------------	-----------------

Server	Power ON/Power OFF
DMS	Creation/Deletion/Resource Reservation/Resource Release/Bulk Resource Release
vRAN	Creation/Modification/Deletion
RU	Change (stop wave/start wave)
Switch	Change

With these functions, we are realizing the optimal resource deployment for energy saving of large-scale and multi-vendor wireless access networks, while balancing the minimization of service impact on users and the shortening of reconstruction time.

#### 3.2.3.1.4 Energy saving effect by optimal resource deployment

In order to demonstrate the effectiveness of the "network service infrastructure technology to realize optimal deployment of vRAN resources", we conducted a computer simulation using a real environment as the evaluation target area. This time, we used the city of Milan, Italy, where available radio wave usage statistics data [27] is published, as the evaluation target area. Figure 6 shows a map of Milan, and the red frame (one side 1 [km]) in the figure was used as the evaluation target area.

Furthermore, the red frame was divided into 16 equal small areas. Similarly, using OpenCellID [28], which is publicly available data on RU placement, we determined the placement of RUs in Milan. In the figure below, macro cells at the cell tower locations are placed in the red circles, and small cells in each RU are placed in the blue circles. UEs were evenly placed in each small area, with 16 UEs each. Figure 3.2.3.1.4-1 shows the RU and UE placement diagram.



Figure 3.2.3.1.4-1: RU/UE layout diagram

The traffic volume of each UE was determined based on The Telecommunication datasets. Figure 4 shows the traffic volume for a weekday. In order to confirm the effect of the proposed technology, it is necessary to set the daytime (peak time) and nighttime

(off-peak time) time zones. In this evaluation, the following two times were set as daytime (peak time) and nighttime (off-peak) respectively.

- Daytime: 1:30 pm when the traffic volume is maximum
- Nighttime: 4:30 am when the traffic volume is minimum

Based on the traffic volume of The Telecommunication datasets at the above time zones, the traffic volume per UE was set as shown in Figure 3.2.3.1.4-2.

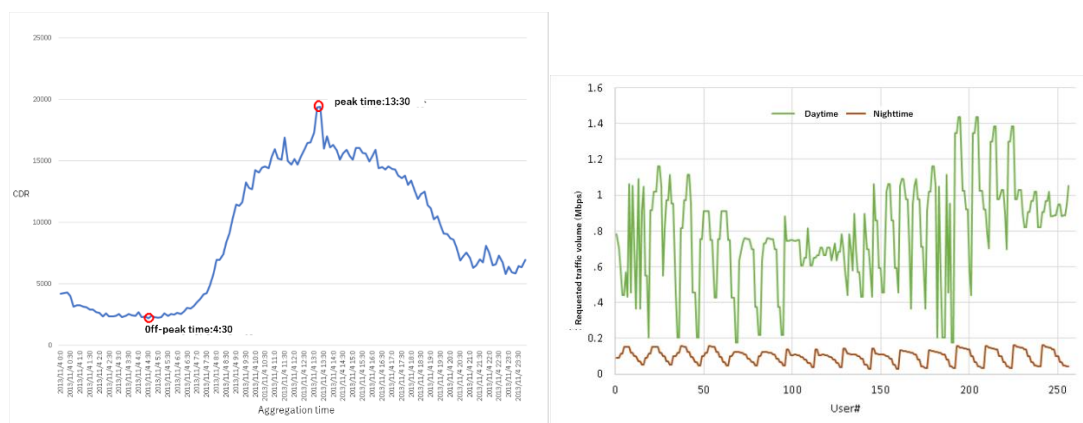

Figure 3.2.3.1.4-2: Traffic volume

The wireless conditions were set as shown in Table 3.2.3.1.4-1.

Table 3.2.3.1.4-1: Wireless condition table

	Bandwidth [MHz]	Center frequency [GHz]	Transmit power [dBm]
RU for macrocell.	20	0.7	48
RU for small cell	100	4.5	25

Figure 3.2.3.1.4-3 shows the operating/stopping status of the RU during the day and night. The solid line connecting the RU and UE indicates the connection relationship.

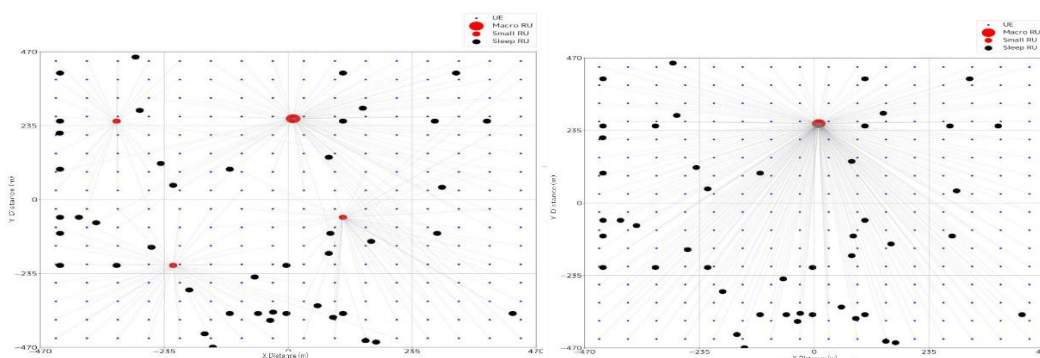

Figure 3.2.3.1.4-3: RU stop status during the day (left) and night (right)

It shows the effect of reducing power consumption by stopping the RU. The number of each device that can be accommodated per 1CU was defined as RU:DU:CU=32:4:1. In other words, when the RU is stopped, the DU and CU are also stopped according to the above number ratio.

Next, the power consumption of each device was defined as shown in Table 3.2.3.1.4-2. The power consumption of the device set to the stop state was set to 0 [W], which is equivalent to the power off, assuming the remote stop/recovery function of the device.

Table 3.2.3.1.4-2: Equipment power consumption table

	RU(macro)	RU(small)	DU	CU
Power consumption during operation [W]	150	200	500	400
Power consumption in stop state[W]	0	0	0	0

In this evaluation, the number of RUs operating in the evaluation target area was 4 during the day and 1 at night. From the equipment configuration ratio, one CU can accommodate 32 RUs, so it can accommodate eight times the evaluation target area. Assuming that there were eight areas similar to the evaluation target area and the RUs were stopped in the same way, the total number of operating units and the total power consumption would be as shown in Table 3.2.3.1.4-3.

Table 3.2.3.1.4-3: Table of operating units and power consumption

	RU(macro)	RU(small)	DU	CU	Total power consumption [W]
Daytime	8	24	4	1	8400
Nighttime	8	0	1	1	2100

Therefore, compared to the conventional case where the RU operates both during the day and at night, the power consumption when the device is stopped at night using the proposed method is about 63 [%], and a reduction of about 37 [%] is possible. From this, it was found that this rApp can be expected to have an energy saving effect.

### 3.2.3.1.5 Conclusion

Sub-clause 3.2.3.1 presents an optimal resource deployment technique for virtualized RAN resources. As a result of the simulation based on this technology, the energy saving effect of about 37% was confirmed. This technology is considered to be effective

for optimal deployment of resources according to the purpose in addition to energy saving. This research result was obtained through research commissioned by National Institute of Information and Communications Technology (NICT) (JPJ012368C04801).

### **3.2.3.2 Other RAN architecture and deployment innovations**

RAN architecture design would have direct or indirect impact to save energy consumption. 6G RAN architecture should also be designed from the viewpoint of energy efficiency. Some potential design principles are provided below [29].

#### ***I. Centralization***

In case of disaggregated RAN architecture, the location of network functions would be relevant to energy consumption. Whilst the RU needs to be installed at the cell site, other network functions in RAN can be placed further back into a more central site such as the edge cloud or a RAN hub site. One drawback of centralization from the energy consumption point of view is the energy required to transport the information to the central site for processing. Nonetheless, central processing can lower energy consumption with statistical pooling gains and lower climate control energy consumption using centralized baseband liquid cooling solutions. Energy consumption for processing and cooling of compute is expected to outweigh energy consumption for optical NW transport.

#### ***II. RAN acceleration for cloud implementation***

Apart from the RAN centralization, implementation of RAN functions into the cloud infrastructure is an emerging trend in the recent deployment, which is most likely a viable deployment for 6G RAN. The cloud native deployment can reduce network operational expenses, and also enables rapid introduction of new services, for example, introducing a new network slice for a particular business or traffic type. On the other hand, implementation of signal processing intensive physical layer functions on a CPU or GPU is not energy efficient. The acceleration with ASICs will be tailored for RAN specific processing to mitigate power consumption, when 6G comes into the market. It is also imperative to support a solution to completely power down the acceleration cards when not in use. Under light traffic conditions, not all deployed acceleration cards will be required to stay active as multiple RUs will be pooled and terminated at the same DU.

#### ***III. Densification***

Coverage densification by small cells (e.g., pico or femto) or multi-TRP base stations can also contribute to energy efficient network. Smaller cells transmit substantially less power than traditional macro base stations. Since the macro supports a wide area, a large number of small cells each consuming a smaller amount of power is required to provide the same coverage. Each small cell

needs to be designed only for a small capacity as the service area is much smaller, thus smaller arrays with fewer layers are sufficient. Similar to RF power, the digital power could also be small. At low loads, the small cells can be switched off dynamically according to traffic patterns within the cell, since only a subset of the small cells will have to serve users, albeit this is only possible where there is umbrella macro coverage.

### 3.2.4 Air-interface Enablers

As analyzed in section 3.1, the energy consumption in RAN is the largest portion in today's network operation. Amongst RAN, the power consumption in an RU is an emerging challenge due to mMIMO deployment that many parts of the physical layer (PHY) signal processing have been shifted into the RU to keep the required fronthaul bandwidth small. Even in the existing 4G/5G radio, there exist some operational solutions by NW implementation. The followings are some examples [23].

#### A. *Micro-discontinuous transmission ( $\mu$ DTX)*

The idea of  $\mu$ DTX is that sparse data traffic is grouped into high power bursts with low backoff, and thereby creating idle transmission periods at which the analog components are pushed into micro-sleep mode.  $\mu$ DTX is hence aimed at improving PA energy consumption in low load regime. Although  $\mu$ DTX can contribute to improve the PA portion of energy consumption in RU (17% as in Figure 4-1), the whole power consumption in RU cannot be close to zero energy operation even in low load. This is because the digital processing power consumption does not decrease with the load since DFE and BB processing platform cannot be pushed into sleep mode.

#### B. *Energy efficient scheduling and link adaptation*

In legacy mobile networks, scheduling and link adaptation (LA) strategies aim at maximizing the spectral efficiency by using MIMO and OFDM with high constellation order and channel coding rate. Whilst it is favorable at peak load, it does not provide the best tradeoff between spectrum efficiency and energy efficiency at medium to high load even in combination with  $\mu$ DTX. An energy efficient scheduling/LA approach, which selects the best combination of energy efficiency functionalities offered by the PHY, can provide significant EE gains particularly in the medium to high load regime. For instance, reducing the average Tx power is preferable over  $\mu$ DTX because the spectrum efficiency is a logarithmic function of the Tx power and linear with respect to the transmission time [26]. Instead of transmitting short bursts each with high spectral efficiency, stretching data transmissions over multiple slots allows a

linear reduction in spectrum efficiency (i.e., reduced constellation size and code rate) but an exponential reduction in the required total radiated power.

### ***C. Antenna muting***

Antenna muting is a technique to limit the number of active Tx chains, depending on the required total radiated power and array gain. The remaining set of active PAs still operates in their optimized low backoff regime. In addition, part of the analog and digital front end can be sent into sleep mode or even deactivated. A key challenge with antenna muting is the loss in antenna gain which affects the coverage. Another challenge is the restriction on the supported number of MIMO layers which affects cell capacity and spectrum efficiency.

In terms of the standard solutions defined in 3GPP, NW energy saving for 5G, i.e., 5G NR, has been studied for their specification in Release 18. The following new features have introduced as the outcome of Release 18 study and specification work [48].

- a. SSB-less SCell in inter-band CA for FR1 and co-located cells  
This feature enables to omit the regular SSB transmission over SCells if co-located with PCell, even in case of inter-band CA.
- b. PDSCH power domain adaptation and antenna adaptation by means of CSI enhancements  
This feature enables the gNB to adjust the Tx power of PDSCH, according to the CSI feedback from UE. Likewise, antenna elements are enabled or disabled, according to the CSI feedback from UE indicating the performance of different candidate antenna patterns.
- c. Cell DTX/DRX  
The functionality of discontinuous transmission and discontinuous reception at gNB is introduced to reduce gNB Tx/Rx activity time.
- d. Inter-node signaling for requesting SSB-beam reactivation  
Per-beam level activation and deactivation is managed via the peer-to-peer signalling between gNBs via Xn interface.
- e. Restricting paging in a limited area of the cell  
With the beam level information where UE is camping on, paging transmission toward UE can be restricted per beam level granularity.
- f. Preventing legacy UEs camping on cells in DTX/DRX operations  
The functionality avoids legacy UEs camping on cells in DTX/DRX operations.



To approach a further drop in energy consumption in mid-to-low load regimes, when a new radio interface is designed for 6G, several innovative directions can be considered [29].

#### I. Adaptive waveforms

OFDM has been a chosen waveform for recent cellular standards, e.g., 4G LTE and 5G NR, especially for downlink. OFDM along with enhancements to compute capabilities enables better spectral efficiency over wider bandwidth and facilitate adoption of MIMO. A drawback of OFDM waveform is its high peak to average power ratio (PAPR), which requires larger backoff in PA operation to achieve better PA linearity at the cost of lower PA efficiency. For uplink, in contrast, a single carrier waveform, i.e., DFT spread OFDM has been used since 4G LTE whose low-PAPR characteristics significantly improved coverage and reduced the power consumption at UE. For 5G NR, both CP-OFDM and DFT spread OFDM are supported for UL, which can be semi-statically configured by NW.

For 6G, support of multiple waveforms can be considered for both downlink and uplink, from which an appropriate one can be chosen depending on the traffic load, e.g., to facilitate energy saving. Figure 3.2.4-1 shows the PAPR of different waveforms without clipping or digital pre-distortion (DPD) operations [29]. The figure reveals the fact that single-carrier waveforms have substantially lower PAPR compared to OFDM. A lower PAPR will translate into better PA efficiency by operating closer to the peak output power of the PA. This can be translated into lower power consumption by adjusting the drain voltage and/or bias current of the PA. At lower loads, there will be no need to multiplex multiple users across the frequency domain. Thus, it will be beneficial to switch from OFDM to a single carrier (SC) waveform such as SC-FDE or SC-FDMA to make energy consumption comparable to that of single carrier systems with narrow bandwidth. Such an adaptive waveform technique has already been discussed for 5G-Advanced in 3GPP. Nevertheless, the technique per se is a viable enabler from the viewpoint of energy efficiency for 6G.

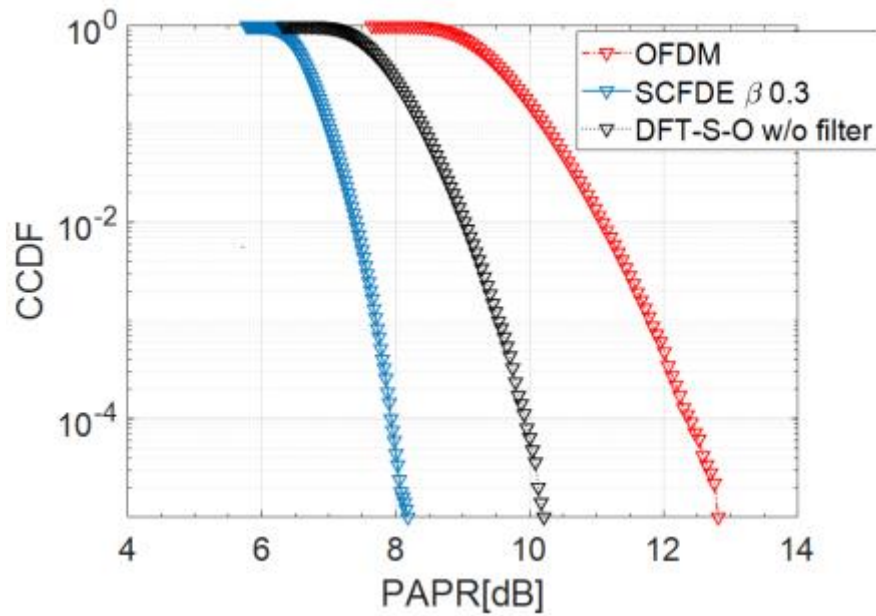

Figure 3.2.4-1: Waveform choices for 6G

II. Adaptive in-band guard sub-carriers

Although the use of multiple waveforms is investigated, it is also worth to explore a technique to balance energy efficiency and spectral efficiency with OFDM. One idea is leveraging some of the in-band tones as guard sub-carriers. In medium or low load regimes, a small subset of sub-carriers is sufficient to transmit data. The rest of unused sub-carriers are the guard bands, as illustrated in Figure 3.2.4-2. By limiting the use of sub-carriers as in the figure, the required spurious emissions are mitigated, resulting in reduced PAPR.

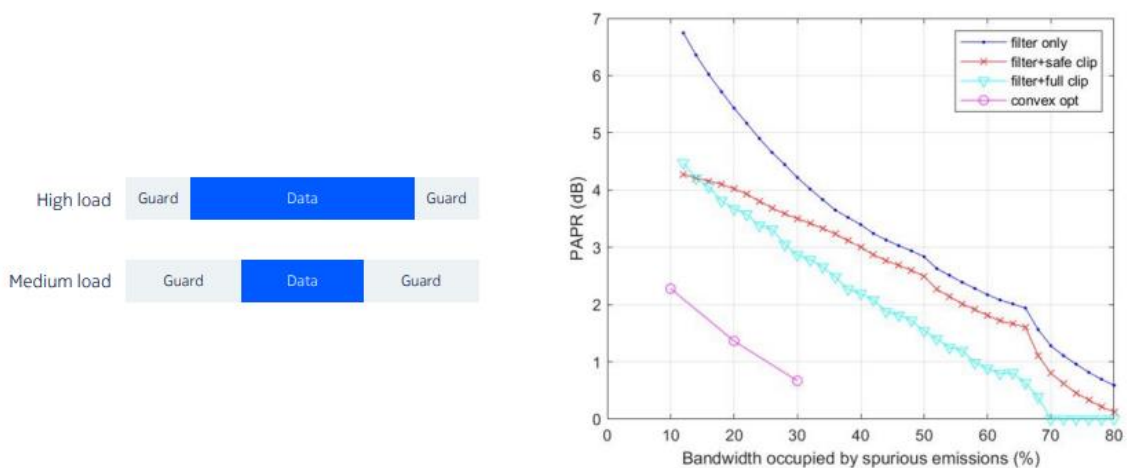

Figure 3.2.4-2: Concept of adaptive in-band guard sub-carriers

III. Database-driven spectrum mask adaptation

An alternative way to increasing the efficiency of PA is to operate it in the non-linear regime with limited or no PA backoff. Nevertheless, one of the challenges to operate PA with the non-linearity is to incur higher out of band emissions. If the requirements on the out of band emissions can be relaxed whenever possible, the PA efficiency is vastly increased. It hinges on whether the adjacent band receivers are in proximity. A spectrum database could be used to learn spectrum occupancy in the adjacent band in the surrounding area. In many cases, the bands adjacent to the cellular bands involve devices that are relatively static or known to follow deterministic trajectories, hence it should be possible to compute their presence in a given area and apply the spectrum mask accordingly.

#### IV. Dynamically scalable arrays

As explained for the antenna muting, one challenging issue when turning off transceivers is the resulting impact on coverage. Typically, the coverage is limited for uplink due to the limited Tx power from UE. It is hence possible to turn off antenna elements on the downlink but maintain the receiver chain to receive uplink signals. Beyond that point, muting will require coverage enhancement solutions such as repeated transmissions. Downlink and uplink coverage should be analyzed for various antenna configurations to determine what additional coverage solutions should be introduced for some of the configurations as needed. If control channel coverage is the limiting factor, then solutions, such as relying on control channels on a different carrier with carrier aggregation, can be considered.

### 3.2.5 Coordination with Non-Terrestrial Network

Current mobile communication traffic continues to increase at an annual rate of 20-30%. Therefore, communication networks in beyond 5G (B5G)/6G era will need to efficiently accommodate the ever-increasing traffic and also promptly provide diverse communication network services such as ultra-high speed, large capacity, ultra-low latency, and multiple simultaneous connections. To enhance the flexibility of network components and fully automate network operations and management, open radio access network (O-RAN) has recently received much attention [30] as a next-generation promising technology for B5G/6G RANs. O-RAN Alliance discusses the specifications of O-RAN, which have two major characteristics: (1) "openness" that enables rapid service provision and incorporation of equipment from multiple vendors, and (2) "intelligence" that enables automation of network operations.

Meanwhile, current mobile networks provide diverse service types handling various frequency bands and coverage scales such as existing 4G-LTE, 5G, and local 5G services, and consequently, the type and the number of base stations (BSs) have continuously been increasing. When 6G services will be commercialized in the future, existing service systems will need to remain in place for the time being, while new 6G BSs will need to be installed. Thus, power consumption of BSs in RANs is a serious problem [30] - [33] and it will be more remarkable in beyond 5G/6G era.

### 3.2.5.1 Conventional O-RAN architecture and Requirement

Figure 3.2.5.1-1 is a schematic diagram of the standard O-RAN architecture [30], in which the components of base stations are separated and interconnected. The components include (i) CU (Central Unit) as a data processing unit, (ii) DU (Distributed Unit) as a radio signal processing unit, and RU (Radio Unit) as an antenna unit, and RIC (RAN Intelligent Controller) as a control unit for the entire O-RAN which performs resource control, service quality control, traffic control, and so on. The RIC is further divided into Near-Realtime (Near-RT) RIC, which requires less than 1 s processing time, and Non-Realtime (Non-RT) RIC which requires more than 1 s processing time. The specified interfaces between each component are (i) A1 between Non-RT RIC and Near-RT RIC, (ii) E2 between Near-RT RIC and CU/DU, (iii) F1 between CU and DU, (iv) O1 between Non-RT RIC and other three components, and (v) Open Fronthaul between DU and RU. UE (User Element) is a mobile terminal, which is connected to the mobile core network and the Internet via the O-RAN. We require to reduce the power consumption of O-RAN BSs while maintaining the continuity of data communications and quality of services for mobile users.

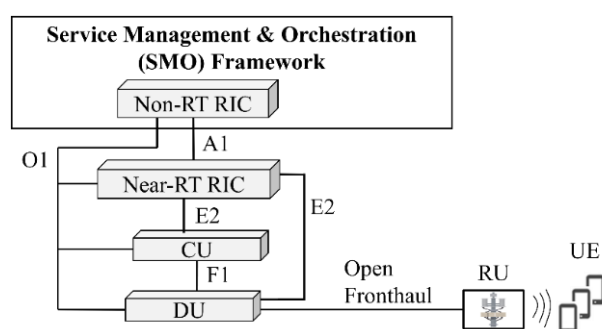

Figure 3.2.5.1-1: Standard O-RAN architecture

### 3.2.5.2 Solution - Power Management for Base Stations Utilizing Pedestrian Flow Analytics and Non-Terrestrial Networks

To address the problem of power consumption of O-RAN, NICT proposes a power management architecture for BSs to realize the BS power-on/-off control utilizing

analytics results of pedestrian flow (i.e., the time-varying number of mobile terminals in the coverage area of each BS) and non-terrestrial networks (NTN) [34] - [36]. Figure 3.2.5.2-1 illustrates a schematic of the proposed architecture, which extends the O-RAN architecture so that the pedestrian flow prediction results and NTN can effectively be utilized to achieve higher energy efficiency. Inside the Non-RT RIC installed in the mobile core, an analytics engine is deployed for each BS and predicts the pedestrian flow in a specific period by learning the past data of pedestrian flow. For example, Long Short-Term Memory can be applied as a deep learning for the prediction. The Non-RT RIC also equips a power scheduling engine to predetermine power-on/-off of multiple BSs for each time. The proposed scheduling algorithm maximizes the number of BSs that can be turned off based on the pedestrian flow prediction results. The Near-RT RIC is deployed in each BS to execute the power-on/-off of the corresponding CU/DU. UEs existing in coverage areas in which the BSs are turned off can access NTN such as LEO (Low Earthe Orbit) and HAPS (High-altitude Platform Station) to reduce the power consumption of O-RAN while maintaining the continuity of data communications, the bitrate, and so on.

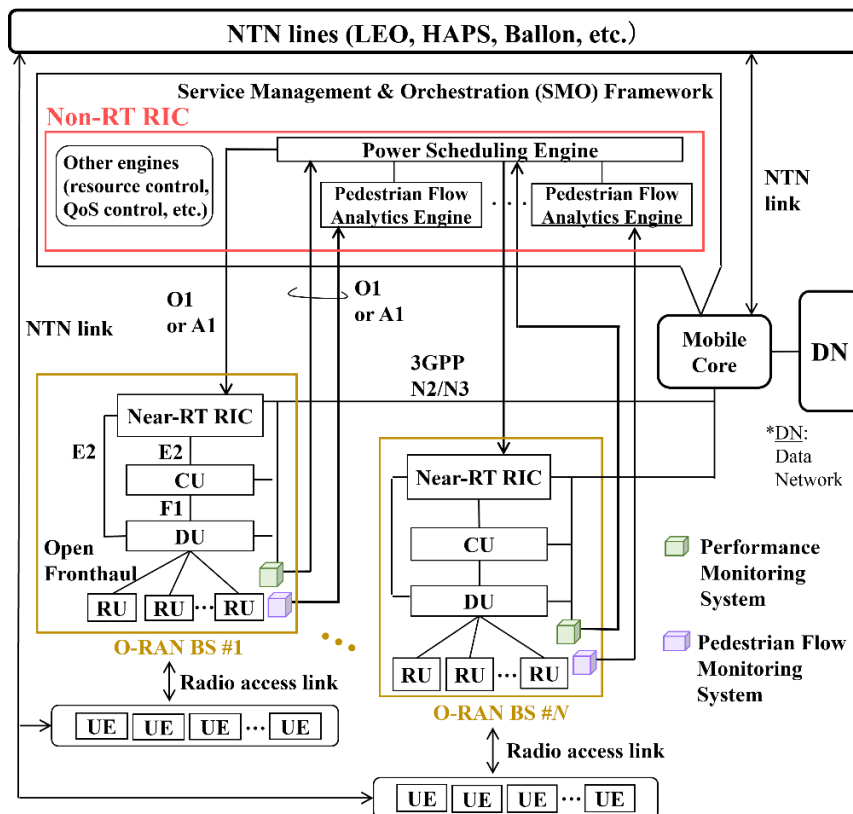

Figure 3.2.5.2-1: Proposed power management architecture

In [34][35], NICT evaluated the power-saving effect obtained by the proposed architecture. KDDI Location Data [37] of 42 mesh areas of Koganei City in Tokyo, were used as real data of pedestrian flow time-varying every 15 minutes. The pedestrian flow for 1 weekday was predicted by training the past 56 weekdays' data. Besides, the database disclosed in [38] was used as mobile traffic data time-varying every hour. The power consumption of CU, DU, and RU were set as 337W, 514W, and 84W, respectively, by using measurement results on a B5G mobile testbed [39], and that of NTN as 2770W. Figure 3.2.5.2-2 shows the relative power consumption of the proposed architecture utilizing NTN, where that of the conventional method turning on all O-RAN BSs without using NTN is set as 1. The communication capacity of NTN was changed in the range from 100 Mbps to 1.3 Gbps. A larger capacity of NTN can accommodate more UEs' traffic, and consequently can turn off more BSs. For example, the proposed architecture can reduce the power consumption by up to 40% when the NTN can accommodate Ues' traffic of 400 Mbps.

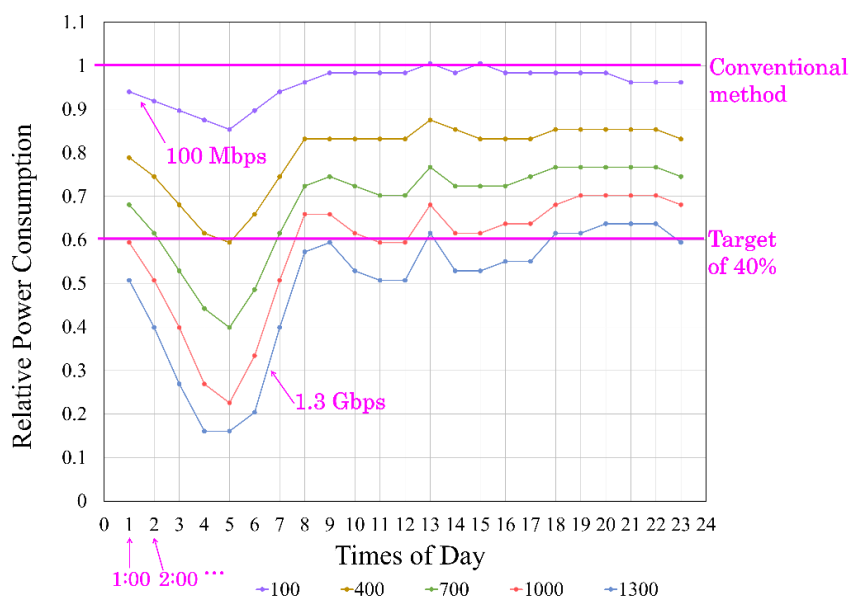

Figure 3.2.5.2-2: Relative power consumption of our proposed architecture

### 3.2.5.3 Conclusion

The proposed power management architecture can highly contribute to energy-saving for O-RANs. In future work, we need to investigate power management for unusual situations such as bad weather, events, and disasters.

## **4. Global Standards for Mobile Communication Networks**

### **4.1 Overall Trend of Energy Efficiency Standardization**

In the field of mobile networks, reducing energy consumption and associated OPEX (operating expenses) has been a crucial challenge for communication service providers. Particularly during large-scale disasters such as earthquakes and tsunamis, ensuring communication means, including emergency call, becomes a vital task even in cases of power loss at base stations. Mobile operators have been working on various measures to address this issue. These efforts are expected to play a significant role in ensuring the sustainability of communication networks and the efficient use of energy as we move towards Beyond 5G/6G.

Furthermore, in the context of Beyond 5G/6G, as communication networks continue to expand and become more densely populated, the introduction of further energy-efficient technologies and improvements in energy efficiency are essential to minimize environmental impact. International standardization bodies, such as the International Telecommunication Union (ITU), the 3<sup>rd</sup> Generation Partnership Project (3GPP), and the O-RAN Alliance, focus on energy efficiency and sustainability as crucial elements in the development of new communication standards, for instance, as defined in the usage scenarios of IMT-2030 defined by ITU-R in Figure 2.3-1. This includes not only the power consumption of base stations and network equipments but also the introduction of low-power devices like IoT, virtualized networks, and other measures. Efforts are also underway to minimize environmental impact through the use of renewable energy and the introduction of technologies to reduce unnecessary energy waste.

#### **4.1.1 3GPP**

3GPP is an organization that promotes the standardization of mobile communication technologies, developing standards for generations such as 3G, 4G, and 5G. Within 3GPP, standardization activities related to Energy Saving and Energy Efficiency have been underway since the LTE era (Rel-8), as part of the efforts within the Self Organized Network (SON) framework.

Functions like Minimization of Drive Test (MDT), which collects information on communication quality from commercial terminals to reduce drive tests, and features that allow to switch off specific cells under certain conditions, such as using OAM (Operation, Administration, and Maintenance) information to ensure predetermined communication quality and coverage (by other base stations or frequencies), have been discussed and standardized in forums like 3GPP SA5 and RAN3.

Furthermore, in the context of 5G/5G Advanced, with the utilization of IoT, big data, and the evolution of AI/ML, there is ongoing consideration of more advanced Energy Saving and Energy Efficiency. In the core network, the introduction of Service-Based Architecture has increased the scalability of Network Functions through virtualization and cloud infrastructure, significantly enhancing the flexibility of network resource management with NW slice functionality, contributing to power consumption optimization.

In the RAN, with the introduction of 5G NR (New Radio) and new frequency bands, as well as communication technologies like beamforming and MIMO, efforts are being made to standardize technologies to maximize energy efficiency alongside expanding frequency utilization efficiency. Initiatives for smart energy management and minimizing energy waste through dynamic network adjustments are also being pursued.

In 3GPP Rel-19, discussions have begun on a Study Item specialized in Energy Efficiency and Energy Saving, where the scope is to identify potential enhancements on 5GS (5G System) including network energy related information exposure, enhancement for subscription and policy control to enable energy efficiency as service criteria and also potential enhancements to take into account the availability of renewable energy may also be considered [41]

#### **4.1.2 O-RAN Alliance**

In the O-RAN Alliance, consideration of Network Energy Saving and Energy Efficiency is also progressing. The O-RAN Alliance further subdivides network devices such as base stations that constitute the Radio Access Network (RAN) defined by 3GPP into logical functional units. It explores the interface specifications for flexible and effective network configurations and commercial deployments using virtualization infrastructure. The alliance is advancing discussions on features that enable more advanced network operations using RAN Intelligent Controller (RIC) and O-Cloud, with Energy Saving/Energy Efficiency being a crucial element in this context.

Within the nodes defined by O-RAN (O-RU, O-DU, O-CU) and the logical components of the network defined by 3GPP (Cell, Carrier, gNB, etc.), research is conducted on the real-time monitoring and reporting of energy consumption and energy efficiency. The following functions are under consideration:

- Switching off/on of carriers and cells
- RF channel reconfiguration
- Selection of advanced sleep modes



- Energy-saving mode for O-Cloud resources

While building upon considerations in 3GPP, the O-RAN Alliance plays a crucial role in achieving even more flexible and advanced Energy Efficiency through the utilization and expansion of RIC and O-Cloud.

#### **4.1.3 ITU and ETSI**

In ITU-T, Study Group 5 (SG5) is the lead study group on EMF, environment, climate action, sustainable digitalization and circular economy, etc. In ITU-T SG5 provides guidance and specifications for the safe and sustainable use of ICT, including ICT products, equipment and installation. SG5 also develops international standards promoting the use of ICT for accelerating a sustainable digital transformation and climate change adaptation and mitigation actions in line with the UN SDG, the UNFCCC Paris Agreement and the Glasgow Climate Pact [42].

In ETSI, the energy efficiency matters are handled by the Technical Committee (TC) Environmental Engineering (EE) which is responsible for defining the equipment engineering, the bonding and grounding, the power supply interface and environmental aspects for telecommunication infrastructures and equipment [43].

There is an energy efficiency related standard jointly developed by ITU-T SG5 and ETSI TC EE. The scope of the joint effort with ITU-T and ETSI is to provide a better understanding of the energy efficiency of mobile networks in particular considering the networks' evolution in different periods of time [44]. The focus of the standard (Recommendation ITU-T L.1331/ ETSI ES 203 228) is on metrics for energy efficiency and methods of assessing (and measuring) energy efficiency in operational networks. For instance, how to measure the energy efficiency ratio is defined from extensive viewpoints, such as, site efficiency, data volume, area coverage, End-to-End latency, number of subscribers, NW slices, etc. [44]. The energy efficiency metrics defined in the standard is applicable to GSM, UMTS, LTE and 5G NR. Furthermore, ETSI has standardized the measurement method for the evaluation of BTS power consumption & energy consumption with static load [45]. For these energy efficiency related standards, the target is NW energy efficiency and UE side is out of the scope.

#### **4.1.4 IETF**

IETF has founded a new program for discussing environmental impacts and sustainability of internet technology, that is, the E-Impact Program [46]. The scope of the E-Impact Program is to investigate trends, issues, improvement opportunities, ideas, best practices, and subsequent direction of work related to Internet technology,

architecture, and operations, including visibility and efficiency on energy and other environmentally impacting attributes. One of the active projects is to outline the guideline of sustainability considerations when designing a new protocols and extensions specified in the IETF standards [47].

#### 4.2 Case Study on Energy Saving through utilization of O-RAN Alliance RIC Research and Development

As a case study for the utilization of Energy Saving in mobile networks, various research and development efforts are underway. Within the NICT (National Institute of Information and Communications Technology) research project titled ‘Research and Development on Frequency Efficiency Improvement through Antenna Transmission Control and Power Control Optimization of Open RAN,’ one of the scopes involves research and development on Energy Saving utilizing the RIC (RAN Intelligent Controller) specified by the O-RAN Alliance. In the context of the Open RAN environment, which becomes even more crucial in Beyond 5G/6G, RIC is positioned as a vital component to enable the autonomous provision of flexible and dynamic services.

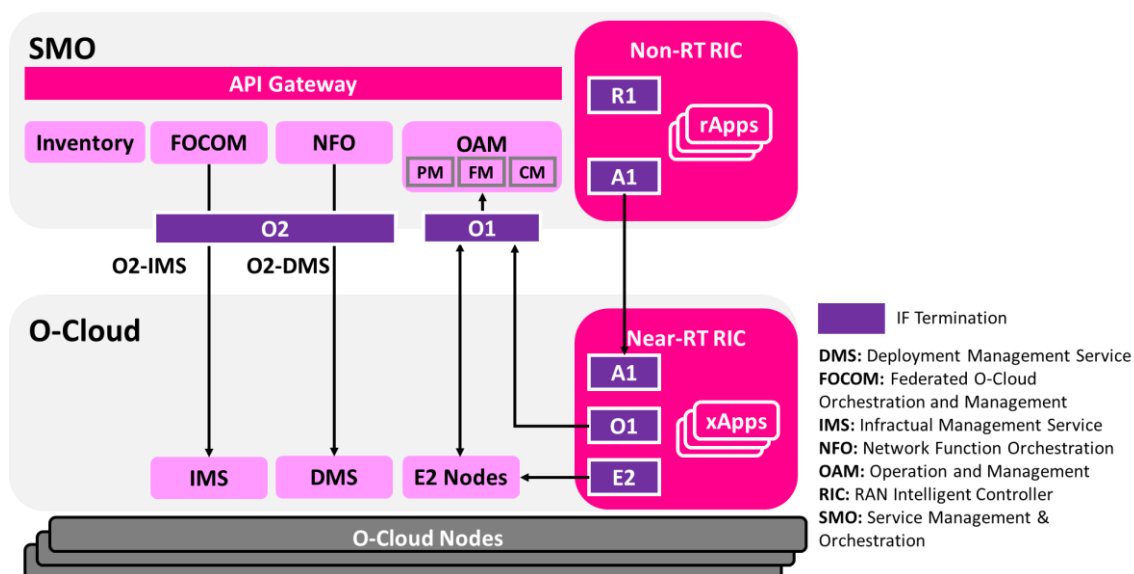

Figure 4.2-1: System Configuration of the RIC Control Platform

Table 4.2-1: Components of the RIC Control Platform

Elements	Summary	Related IF
<b>Near-RT RIC</b>	Near-real-time RIC implementation compliant with O-RAN.WG3.RICARCH.	A1/E2/O1
<b>Non-RT RIC</b>	Non-real-time RIC implementation compliant with O-RAN.WG2.Non-RT-RIC-ARCH.	A1/R1

<b>O-Cloud</b>	IMS (Infrastructure Management Services): manages O-Cloud resources and resource management software.	O2-IMS
	DMS (Deployment Management Services): Manages NF Deployment on O-Cloud, providing functions such as instantiating, monitoring, and stopping NF Deployment.	O2-DMS
<b>API Gateway</b>	API gateway functionality. Northband system integration.	R1
<b>AI/DATA Platform</b>	Provides AI/ML and data analysis functions, AI/ML model training, AI support resource optimization, and AI support recommendations on LCM and rApp.	A1
<b>inventory</b>	Provides Inventory Management (IM) functionality for CU, DU, RU, O-Cloud, rApp, xApp, RAN data, etc.	
<b>FOCOM</b> (Federated O-Cloud Orchestration)	Work with LCM and Inventory to provide management capabilities for O-Cloud's infrastructure resources and software.	O2-IMS
<b>NFO (Network Function Orchestration)</b> (Network Function Orchestration)	Provides NF Deployments management functionality on the O-Cloud for a collection of Network Functions (NF) in conjunction with LCM and Inventory.	O2-DMS
<b>OAM (Operation and Management)</b> (Operation and Management (OAM))	Provides Fault Management (FM) functionality.	O1/O2
	Provides Performance Management (PM) functionality.	O1/O2
	Provides Configuration Management (CM) functionality.	O1-CM
	Provide Observability. Example: O-RAN/O-Cloud logs, metrics/KPIs, traces, etc. to be collected via O1/O2.	O1-FM/O1-PM/ O2-FM/O2-PM

In the consideration of Energy Saving in mobile communication systems, including Open RAN, it is crucial to establish platforms and environments that implement various functions to reduce the power consumption of RAN (Radio Access Network) devices. This includes real-time monitoring and analysis of the utilization of various resources such as cloud servers, as well as traffic conditions. Utilizing Artificial Intelligence (AI) and Machine Learning (ML), a platform for implementing appropriate control based on real-time monitoring becomes essential.

In this research and development, the focus is on the development of a power control system based on ML for real-time analysis of service models and base station configurations. Additionally, a big data platform is being developed to collect power

consumption data from RAN and core networks, as well as user traffic. The goal is to demonstrate a power reduction of over 10% across the entire network, contributing to improved frequency efficiency, with the baseline being the scenario where the power control system is not utilized. The following outlines the power control-related functions that constitute the scope of this research and development:

- “Cell/Carrier Switch On/Off”: Based on predictions or current load conditions, specific cells/carriers are turned off to reduce the power consumption of the Radio Access Network (RAN). For instance, in scenarios where capacity cells (aimed at capacity enhancement) are completely overlaid by coverage cells (aimed at coverage provision), as described in Section 5.1.3.3 of 3GPP TS 28.310, capacity cells can be turned off during low-traffic times to offload all communication to coverage cells.
- “RF Channel Reconfiguration”: Based on predictions or current load conditions, control of the number of transmission channels in the Radio Frequency (RF) is adjusted to reduce the power consumption of the RAN. For example, during periods of low traffic, the MIMO channel count can be changed from 4x4 to 2x4.
- “Advanced Sleep Modes”: Based on predictions or current load conditions, power-saving states of the O-RAN Radio Unit (O-RU) are controlled according to the Advanced Sleep Modes under consideration by the O-RAN Working Group 1’s Use Case Task Group. This helps in reducing the power consumption of the RAN.
- “Cloud Resource Energy Saving”: Based on predictions or current load conditions, power-saving states of various components in the edge cloud (e.g., C-states for CPU) are controlled to reduce the power consumption of the edge cloud.

The Cell OFF function involves the following operating principles:

- Specific Cell Deactivation: The function identifies specific cells within the network and deactivates them.
- Power Consumption Reduction: The primary objective is to reduce the power consumption of the Radio Access Network (RAN).
- Example Scenario: As an illustration, during low-traffic periods, the function may deactivate capacity cells (cells designed for capacity enhancement) if they are entirely overlaid by coverage cells (cells designed for coverage provision). This action facilitates the offloading of all communications to the coverage cells, optimizing power usage in the network.

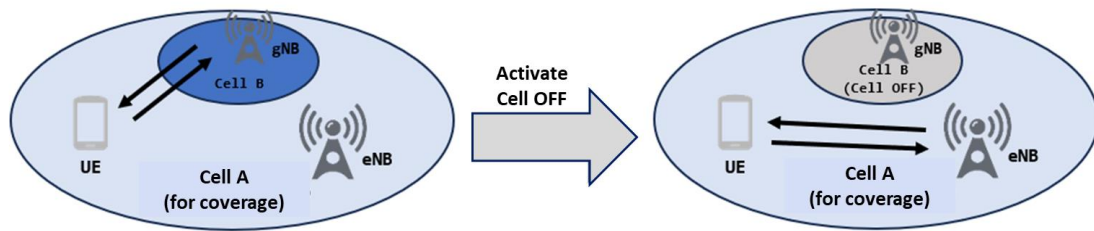

Figure 4.2-2: Overview of the Cell OFF Function

To achieve maximum power savings across the entire network, it is crucial to flexibly and dynamically select the most optimal sleep modes for each cell, taking into account variations in traffic load. Leveraging the Cell OFF function and offloading User Equipment (UE) being serviced to a coverage cell covering the same area as the current serving cell is expected to further reduce the power consumption of capacity cells. This approach allows for consideration of traffic load fluctuations in each cell and aims to enhance power efficiency.

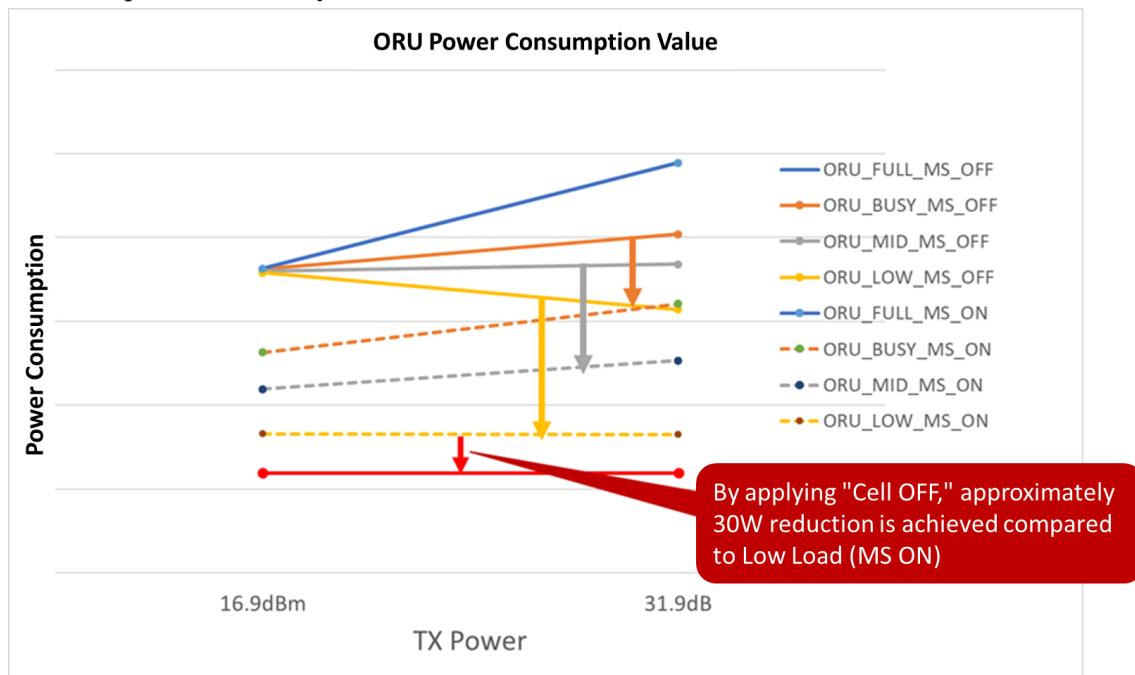

Figure 4.2-3: Power reduction example with Cell OFF [W]

Furthermore, power control technologies for the edge cloud are also crucial. Dynamic control of CPU cores and operating frequencies based on traffic trends, without impacting the performance of the control plane and user plane, is being pursued. Additionally, advancements include dynamic orchestration techniques for virtual network functions based on traffic demand and predictions, along with verification of power control effects in the edge cloud contributing to improved energy efficiency.

The research in this section was supported by Japan government. Part of the research results were obtained from the commissioned research (No. JPJ012368C06501) by National Institute of Information and Communications Technology (NICT), Japan.

## 5. Acknowledgements

This White Paper was prepared with the generous support of many people who participated in the White Paper Subcommittee. The cooperation of telecommunications industry players and academia experts, as well as representatives of various industries other than the communications industry has also been substantial. Thanks to everyone's participation and support, this White Paper was able to cover a lot of useful information for future business creation discussions between the industry, academia, and government, and for investigating solutions to social issues, not only in the telecommunications industry, but also across all industries. We hope that this White Paper will help Japan create a better future for society and promote significant global activities.

## 6. References

- [1] United Nations Sustainable Development Goals  
<https://sdgs.un.org/goals>
- [2] Copernicus, "Global Climate Highlights 2023 – The 2023 annual climate summary,"  
<https://climate.copernicus.eu/global-climate-highlights-2023#:~:text=2023%20is%20the%20warmest%20year,larger%20than%20the%20ERA5%20value.>
- [3] Japan Meteorological Agency webpage (Japanese)  
[https://www.data.jma.go.jp/cpdinfo/temp/an\\_jpn.html](https://www.data.jma.go.jp/cpdinfo/temp/an_jpn.html)
- [4] Paris agreement on climate change  
<https://sdgs.un.org/frameworks/parisagreement>
- [5] MIC, "Overview of the 2022 White Paper on Information and Communications in Japan,"  
<https://www.soumu.go.jp/johotsusintokei/whitepaper/eng/WP2022/fullversion.pdf>
- [6] Beyond 5G Promotion Contortium, "Beyond 5G White Paper – Message to the 2030s-," version 2.0, March 13, 2023  
[https://b5g.jp/doc/whitepaper\\_en\\_2-0.pdf](https://b5g.jp/doc/whitepaper_en_2-0.pdf)
- [7] S. Mukherjee, "Creating the future: maximizing our handprint and minimizing our footprint," Nokia Blog, Jun 2023.  
<https://www.nokia.com/blog/creating-the-future-maximizing-our-handprint-and-minimizing-our-footprint/>
- [8] The World Bank report, December 2023

<https://documents.worldbank.org/en/publication/documents-reports/documentdetail/099121223165540890/p17859702a98880540a4b70d57876048abb>

[9] “Artificial intelligence explained,” Nokia article, Dec 2023.

<https://www.nokia.com/about-us/newsroom/articles/artificial-intelligence-explained/>

[10] [https://en.wikipedia.org/wiki/Environmental,\\_social,\\_and\\_corporate\\_governance](https://en.wikipedia.org/wiki/Environmental,_social,_and_corporate_governance)

[11] Recommendation ITU-R M.2160-0 (11/2023), “Framework and overall objectives of the future development of IMT for 2030 and beyond,”

[https://www.itu.int/dms\\_pubrec/itu-r/rec/m/R-REC-M.2160-0-202311-I!!MSW-E.docx](https://www.itu.int/dms_pubrec/itu-r/rec/m/R-REC-M.2160-0-202311-I!!MSW-E.docx)

[12] Omer, et. al., “Towards Sustainable and Trustworthy 6G – Challenges, Enablers and Architectural Design,”

<https://www.nowpublishers.com/article/DownloadEBook/9781638282389?format=pdf>

[13] Recommendation ITU-T L.1410 (12/2014), “Methodology for environmental life cycle assessments of information and communication technology goods, networks and services,”

[https://www.itu.int/rec/dologin\\_pub.asp?lang=e&id=T-REC-L.1410-201412-I!!PDF-E&type=items](https://www.itu.int/rec/dologin_pub.asp?lang=e&id=T-REC-L.1410-201412-I!!PDF-E&type=items)

[14] Hexa-X Deliverable D1.1, “6G Vision, use cases and key societal values,”

[https://hexa-x.eu/wp-content/uploads/2021/02/Hexa-X\\_D1.1.pdf](https://hexa-x.eu/wp-content/uploads/2021/02/Hexa-X_D1.1.pdf)

[15] 6G-IA, “What societal values with 6G address? – Societal Key Values and Key Value Indicators analysed through 6G use cases,”

<https://5g-ppp.eu/wp-content/uploads/2022/05/What-societal-values-will-6G-address-White-Paper-v1.0-final.pdf>

[16] Next G Alliance Report, “6G Sustainability KPI Assessment – Introduction and Gap Analysis,”

[https://www.nextgalliance.org/white\\_papers/6g-sustainability-kpi-assessment-introduction-and-gap-analysis/](https://www.nextgalliance.org/white_papers/6g-sustainability-kpi-assessment-introduction-and-gap-analysis/)

[17] Nokia, et. al., “Proposals on key value indicator description in working document towards preliminary draft new recommendation ITU-R M.[IMT.vision 2030 and beyond],” Document 5D/1653-E, 25<sup>th</sup> Jan, 2023.

[https://www.itu.int/dms\\_ties/itu-r/md/19/wp5d/c/R19-WP5D-C-1653!!MSW-E.docx](https://www.itu.int/dms_ties/itu-r/md/19/wp5d/c/R19-WP5D-C-1653!!MSW-E.docx)

[18] 3GPP S1-233584, “Addressing KVIs in SA1 Rel-20,” Nokia, Nokia Shanghai Bell.

[https://www.3gpp.org/ftp/tsg\\_sa/WG1\\_Serv/TSGS1\\_104\\_Chicago/Docs/S1-233584.zip](https://www.3gpp.org/ftp/tsg_sa/WG1_Serv/TSGS1_104_Chicago/Docs/S1-233584.zip)

[19] V. Ziegler, P. Schneider, H. Viswanathan, M. Montag, S. Kanugovi and A. Rezaki, “Security and Trust in the 6G Era,” in IEEE Access, vol. 9, pp. 142314-142327, 2021, doi: 10.1109/ACCESS.2021.3120143.

<https://ieeexplore.ieee.org/document/9570274>

- [20] S. Yu, H. Jiang, S. Huang, X. Peng and A. Lu, "Compute-in-Memory Chips for Deep Learning: Recent Trends and Prospects," IEEE Circuits and Systems Magazine, vol. 21, pp. 31-56, Aug. 2021.  
<https://ieeexplore.ieee.org/document/9512855>
- [21] Green Future Networks: Network Energy Efficiency – NGMN, Dec. 2021.  
<https://www.ngmn.org/wp-content/uploads/211009-GFN-Network-Energy-Efficiency-1.0.pdf>
- [22] Further Study on Critical C-RAN Technologies, NGMN, Mar. 2015.  
[https://www.ngmn.org/wp-content/uploads/NGMN\\_RANEV\\_D2\\_Further\\_Study\\_on\\_Critical\\_C-RAN\\_Technologies\\_v1.0.pdf](https://www.ngmn.org/wp-content/uploads/NGMN_RANEV_D2_Further_Study_on_Critical_C-RAN_Technologies_v1.0.pdf)
- [23] S. Wesemann, J. Du and H. Viswanathan, "Energy Efficient Extreme MIMO: Design Goals and Directions," in IEEE Communications Magazine, vol. 61, no. 10, pp. 132-138, October 2023, doi: 10.1109/MCOM.004.2200958.  
<https://ieeexplore.ieee.org/document/10179153>
- [24] 3GPP SP-211621, "LS on Energy Efficiency as guiding principle for new solutions," TSG SA.  
[https://www.3gpp.org/ftp/tsg\\_sa/TSG\\_SA/TSGS\\_94E\\_Electronic\\_2021\\_12/INBOX/SP-211621.zip](https://www.3gpp.org/ftp/tsg_sa/TSG_SA/TSGS_94E_Electronic_2021_12/INBOX/SP-211621.zip)
- [25] 3GPP SP-231192, "New SID on 5GS Enhancement for Energy Efficiency and Energy Saving," Samsung (Moderator).  
[https://www.3gpp.org/ftp/tsg\\_sa/TSG\\_SA/TSGs\\_101\\_Bangalore\\_2023-09/INBOX/SP-231192.zip](https://www.3gpp.org/ftp/tsg_sa/TSG_SA/TSGs_101_Bangalore_2023-09/INBOX/SP-231192.zip)
- [26] M. Sao., H. Watanabe., Y. Musha., A. Utsunomiya., "Application of Digital Annealer for Faster Combinatorial Optimization". Fujitsu Scientific and Technical Journal. 2019, Vol. 55, No.2, 45-51.
- [27] G. Barlacchi., M. D. Nadai., R. Larcher., A. Casella., C. Chitic., G. Torrisi., F. Antonelli., A. Vespignani., A. Pentland., B. Lepri., "A multi-source dataset of urban life in the city of Milan and the Province of Trentino" . Scientific Data.
- [28] Unwired Labs. "OpenCellID - Largest Open Database of Cell Towers & Geolocation - by Unwired Labs" . OpenCellid.
- [29] H. Viswanathan, S. Wesemann, J. Du and H. Holma, "Energy efficiency in next-generation mobile networks," Nokia White paper, Nov 2022.  
<https://onestore.nokia.com/asset/212810>
- [30] O-RAN Alliance, [www.o-ran.org/](http://www.o-ran.org/)
- [31] 3GPP TS 28.310 v18.1.0 (March 2023)
- [32] X. Tan, et al., IEEE TGCN, vol.7, issue 3, pp.1250-1266, Sep. 2023.
- [33] S. Zeb, et al., Proc. of NetMan6G, Madrid, Spain, Dec. 2021.



- [34] T. Miyazawa et al., IEICE Technical Report, RCS2023-124, Nagano, Japan, Aug. 2023.
- [35] T. Miyazawa et al., Proc. of ICETC 2023, Sapporo, Japan, Dec. 2023.
- [36] T. Miyazawa et al., IEICE Technical Report, SR2023-50, Sendai, Japan, Nov. 2023.
- [37] KDDI Location Data, [k-locationdata.kddi.com/](http://k-locationdata.kddi.com/)
- [38] [www.soumu.go.jp/johotsusintokei/english/](http://www.soumu.go.jp/johotsusintokei/english/)
- [39] H. Harai et al., IEICE Technical Report, NS2022-63, Sendai, Japan, Sep. 2022.
- [40] <https://www.itu.int/en/ITU-R/study-groups/rsg5/rwp5d/imt-2030/Pages/default.aspx>
- [41] 3GPP TR 23.700-66 Study on Energy Efficiency and Energy Saving(Release 19)
- [42] ITU-T SG5 Webpage, <https://www.itu.int/en/ITU-T/studygroups/2022-2024/05/Pages/default.aspx>
- [43] ETSI TC EE Webpage, <https://www.etsi.org/committee/1395-ee>
- [44] Recommendation ITU-T L.1331/ETSI ES 203 228 v1.4.1 (2022-04), “Assessment of mobile network energy efficiency,”
- [45] ETSI ES 202 706-1 v1.7.1 (2022-08), “Metrics and measurement method for energy efficiency of wireless access network equipment; Part 1: Power consumption - static measurement method,”
- [46] IETF Environmental Impacts of Internet Technology (eimact)  
<https://datatracker.ietf.org/program/eimact/about/>
- [47] Nokia, et. al., “Sustainability Considerations for Internetworking,” IETF NW WG, Internet-Draft.  
<https://datatracker.ietf.org/doc/draft-cparsk-eimact-sustainability-considerations/>
- [48] 3GPP RP-233657, “WI summary for Network energy saving for NR,” Huawei.  
[https://www.3gpp.org/ftp/tsg\\_ran/TSG\\_RAN/TSGR\\_102/Docs/RP-233657.zip](https://www.3gpp.org/ftp/tsg_ran/TSG_RAN/TSGR_102/Docs/RP-233657.zip)

## **7. Contributing Authors**

Chapter 3.2.3.1: Optimal deployment planning technology for vRAN resources, exemplified by energy saving

Fujitsu Limited: Masayuki Satsu and Tatsuaki Oyabu

Chapter 3.2.5: Coordination with Non-Terrestrial Network (Power Management for Base Stations Utilizing Pedestrian Flow Analytics and Non-Terrestrial Networks)

National Institute of Information and Communications Technology: Takaya Miyazawa

Chapter 4: Global Standards for Mobile Communication Networks

Rakuten Mobile: Kenichiro Aoyagi

Others:

Nokia: Hideaki Takahashi, Ali Rezaki, Daniela Laselva, Gerald Kunzmann, Jinfeng Du, Kimmo Kettunen, Laurent-Walter Goix, Navin Hathiramani, Olivier Guyot, Satish K., Shohreh Ahvar

## Abbreviation List

Abbreviation	Explanation
<b>3GPP</b>	Third Generation Partnership Project
<b>AI</b>	Artificial Intelligence
<b>API</b>	Application Programming Interface
<b>APs</b>	Access Points
<b>AR</b>	Augmented Reality
<b>ASIC</b>	Application Specific Integrated Circuit
<b>BS</b>	Base Station
<b>BTS</b>	Base Transceiver Station
<b>CA</b>	Carrier Aggregation
<b>CK-MARL</b>	Constrained KPI-managing Multi-Agent Reinforcement Learning
<b>CN</b>	Core Network
<b>CPU</b>	Central Processing Unit
<b>CSI</b>	Channel State Information
<b>CSP</b>	Communication Service Provider
<b>CU</b>	Central Unit
<b>DFE</b>	Digital Front End
<b>DFT</b>	Discrete Fourier Transform
<b>DRX</b>	Discontinuous Reception
<b>DTX</b>	Discontinuous Transmission
<b>DU</b>	Distributed Unit
<b>EMF</b>	Electromagnetic Field
<b>ESG</b>	Environmental, Social and (corporate) Governance
<b>ETSI</b>	European Telecommunications Standards Institute
<b>FDE</b>	Frequency Domain Equalization
<b>FDMA</b>	Frequency Division Multiple Access
<b>FFT</b>	Fast Fourier Transform
<b>FR</b>	Frequency Range
<b>GEO</b>	Geostationary Orbit
<b>GHG</b>	Green House Gas
<b>GPU</b>	Graphics Processing Unit

<b>Abbreviation</b>	<b>Explanation</b>
<b>GSM</b>	Global System for Mobile communication
<b>HAPS</b>	High Altitude Platform Station
<b>IETF</b>	Internet Engineering Task Force
<b>I/F</b>	Interface
<b>IC</b>	Integrated Circuit
<b>ICT</b>	Information and Communication Technology
<b>IoT</b>	Internet of Things
<b>IMT</b>	International Mobile Telecommunications
<b>IT</b>	Information Technology
<b>ITU</b>	International Telecommunication Union
<b>ITU-R</b>	ITU Radiocommunication sector
<b>ITU-T</b>	ITU Telecommunication standardization sector
<b>KPI</b>	Key Performance Indicator
<b>KV</b>	Kay Value
<b>KVI</b>	Key Value Indicator
<b>LEO</b>	Low Earth Orbit Satellite
<b>LTE</b>	Long Tern Evolution
<b>MDT</b>	Minimization of Drive Test
<b>MIC</b>	Ministry of Internal affairs and Communications
<b>MIMO</b>	Multiple-Input and Multiple-Output
<b>mMIMO</b>	massive MIMO
<b>ML</b>	Machine Learning
<b>NF</b>	Network Function
<b>NR</b>	New Radio
<b>NTN</b>	Non-Terrestrial Network
<b>NW</b>	Network
<b>OFDM</b>	Orthogonal Frequency Division Multiplexing
<b>OPEX</b>	Operating Expense
<b>O-RAN</b>	Open Radio Access Network
<b>PA</b>	Power Amplifier
<b>PAPR</b>	Peak to Average Power Ratio

<b>Abbreviation</b>	<b>Explanation</b>
<b>PCell</b>	Primary Cell
<b>PDSCH</b>	Physical Downlink Shared Channel
<b>PHY</b>	Physical Layer
<b>QoS</b>	Quality of Service
<b>RAN</b>	Radio Access Network
<b>rApp</b>	Non-RT RIC Application
<b>RAT</b>	Radio Access Technology
<b>RF</b>	Radio Frequency
<b>RFIC</b>	Radio Frequency Integrated Circuit
<b>RIC</b>	RAN Intelligent Controller
<b>RT</b>	Real Time
<b>RU</b>	Radio Unit
<b>SCell</b>	Secondary Cell
<b>SDGs</b>	Sustainable Development Goals
<b>SMO</b>	Service Management and Orchestration
<b>SON</b>	Self Organized Network
<b>SSB</b>	SS/PBCH block
<b>TRP</b>	Transmission Reception Points
<b>UE</b>	User Equipment
<b>UMTS</b>	Universal Mobile Telecommunication System
<b>UN</b>	United Nations
<b>UNFCCC</b>	United Nations Framework Convention on Climate Change
<b>vRAN</b>	Virtual Radio Access Network